

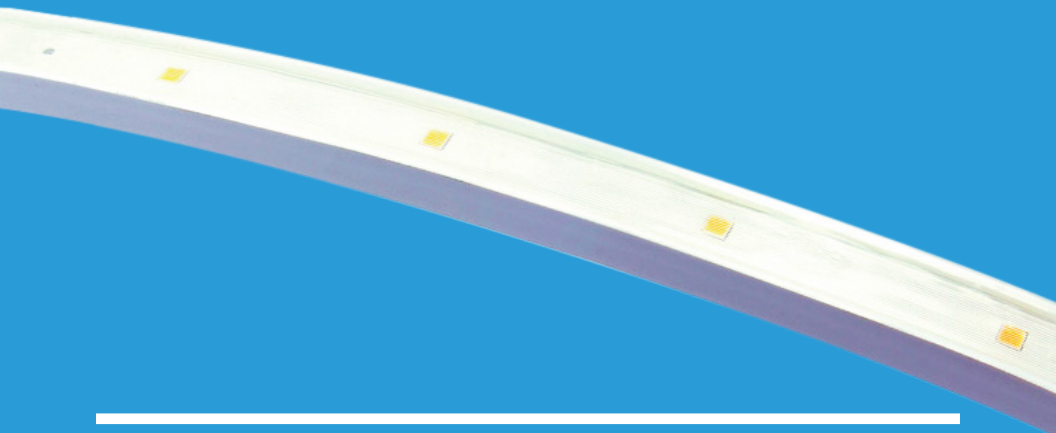

BRILLIANCE[®]
LED
A HIGHER LIGHT FORM[®]

STRIP LIGHT GUIDE



CUT SHEET

DESCRIPTION:

The Brilliance LED AC (TPU-Gen III) Strip Light is rated for outdoor use and can be directly connected to an existing 8-16 VAC landscape lighting system. Great accent lighting for stairs, railings and overhangs. The LEDs on this Strip Light are encased in non-yellowing material that installs easily.

FEATURES:

- Dimmable with most magnetic transformers
- Max length for power feed is 12m (39' 4")
- Available in 25 meter reels or custom cut to specific lengths

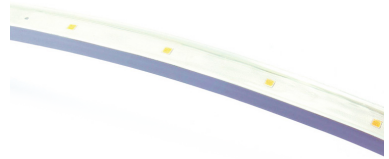

PART NUMBER : BRI SL3 XXXX XX 65

2700
5000
red
green
blue

KELVIN TEMPERATURE
LENGTH (measurement in meters)

Wattage	1.8 per meter
Lumens	144 (45/ft)
Kelvin Temperature	2700, 5000
Color	red, green, blue
Operating Range	8-16 VAC
CRI	75
IP	65
Lamp Life (hours)	35,000
Warranty (years)	3

Brilliance LED 3rd Generation Strip Light Dimensions:

30 cm Example without end connections
(may be cut at each 3 LED section - 10 cm)

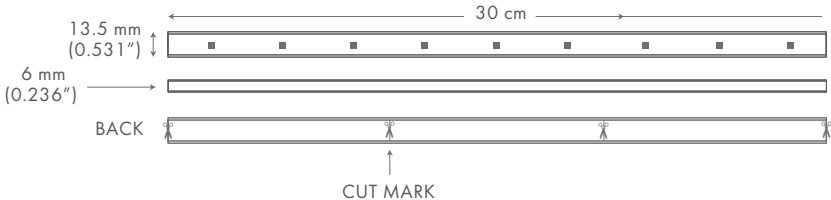

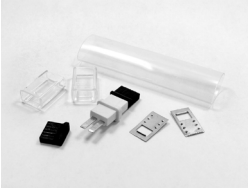

Double-Sided Connector Kit

- Part # - 0 35127 47542 4
- 1 - Double-Sided Connector
 - 2 - Clear Plastic Retainers
 - 2 - Metal Anti-Slip Plates
 - 1 - Heat Shrink Tube

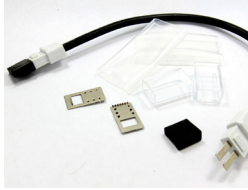

Jumper Connector Kit

- Part # - 0 35127 47606 3
- 1 - Jumper Connector
 - 2 - Clear Plastic Retainers
 - 2 - Metal Anti-slip Plates
 - 2 - Heat-shrink Tubes

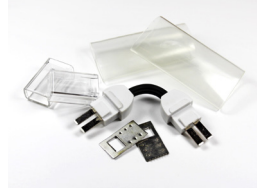

90° Jumper Connector Kit

- Part # - 0 35127 47698 8
- 1 - Jumper Connector
 - 2 - Clear Plastic Retainers
 - 2 - Metal Anti-slip Plates
 - 2 - Heat-shrink Tubes



Power Feed Kit

- Part # - 0 35127 47544 8
- 1 - Power Feed
 - 1 - Clear Plastic Retainer
 - 1 - Metal Anti-slip Plate
 - 1 - Heat-shrink Tube



"T" Power Feed Connector Kit

- Part # - 0 35127 47608 7
- 1 - "T" Power Feed Connector
 - 2 - Clear Plastic Retainers
 - 2 - Metal Anti-slip Plates
 - 2 - Heat-shrink Tubes

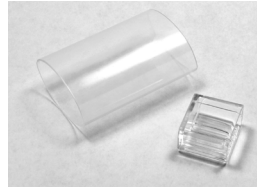

End Cap Kit

- Part # - 0 35127 47607 0
- 1 - End Cap
 - 1 - Light Shield
 - 1 - Heat-shrink Tube



Extrusion Kit

- Part # - 0 35127 47611 7
- 1m (3.2') Extrusion sections



Clip & Screw Kit

- Part # - 0 35127 47543 1
- 50 - Plastic Clips
 - 100 - Screws

INSTRUCTIONS

STEP 1: Place heat shrink tube & clear retainer on strip light.

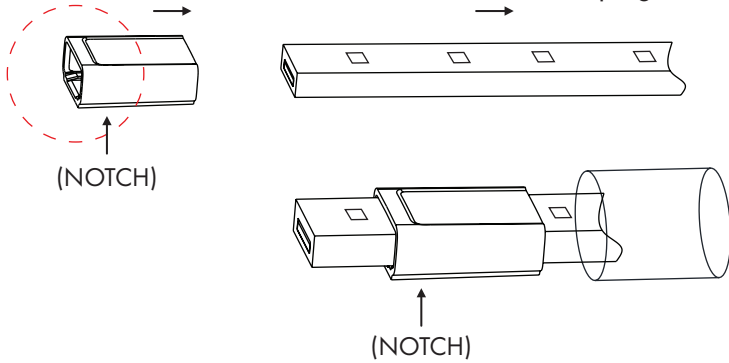

STEP 2: Connect power feed to strip light.

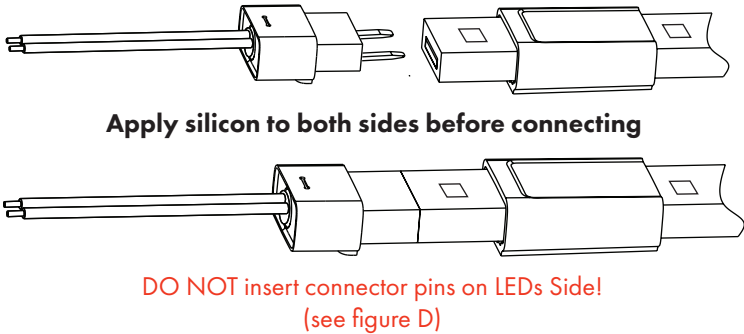

STEP 3: Place metal anti-slip plate & slide clear retainer over.

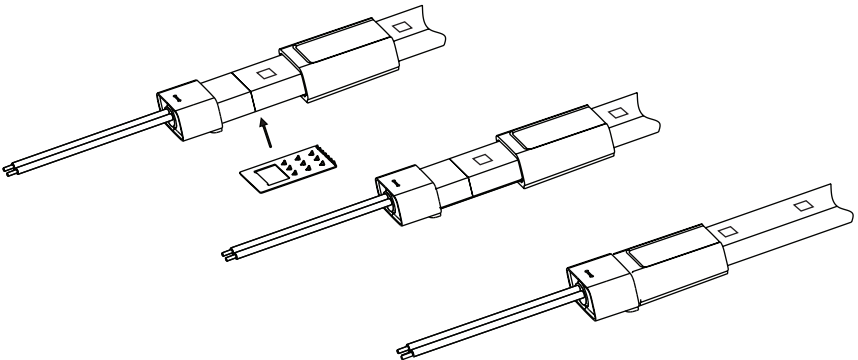

INSTRUCTIONS

STEP 4: Cover with heat shrink tube & seal with heat gun.

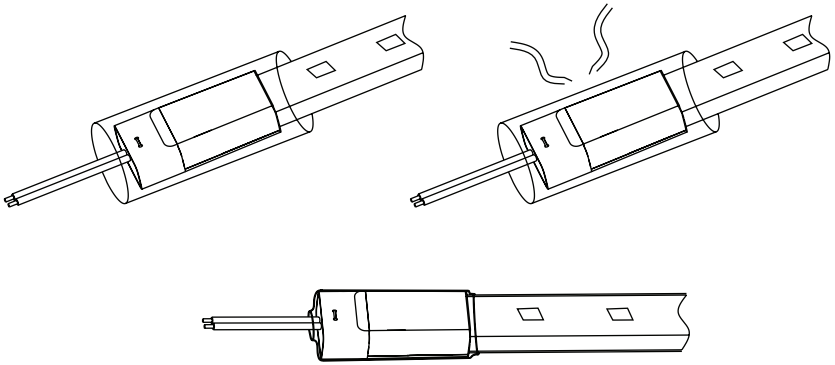

STEP 5: Cover with heat shrink tube & seal with heat gun.

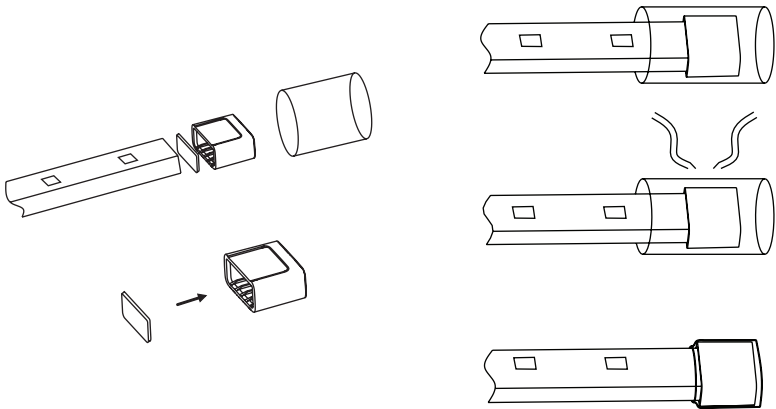

FIGURES

FIGURE A: Accessories

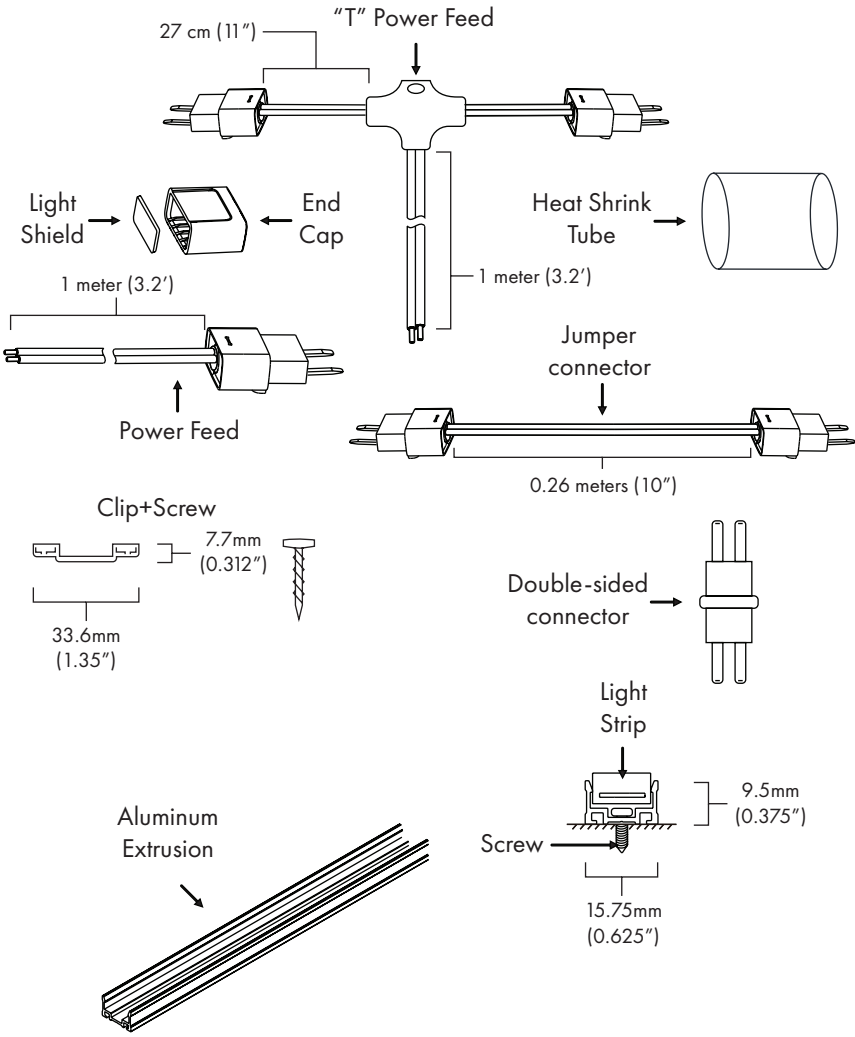
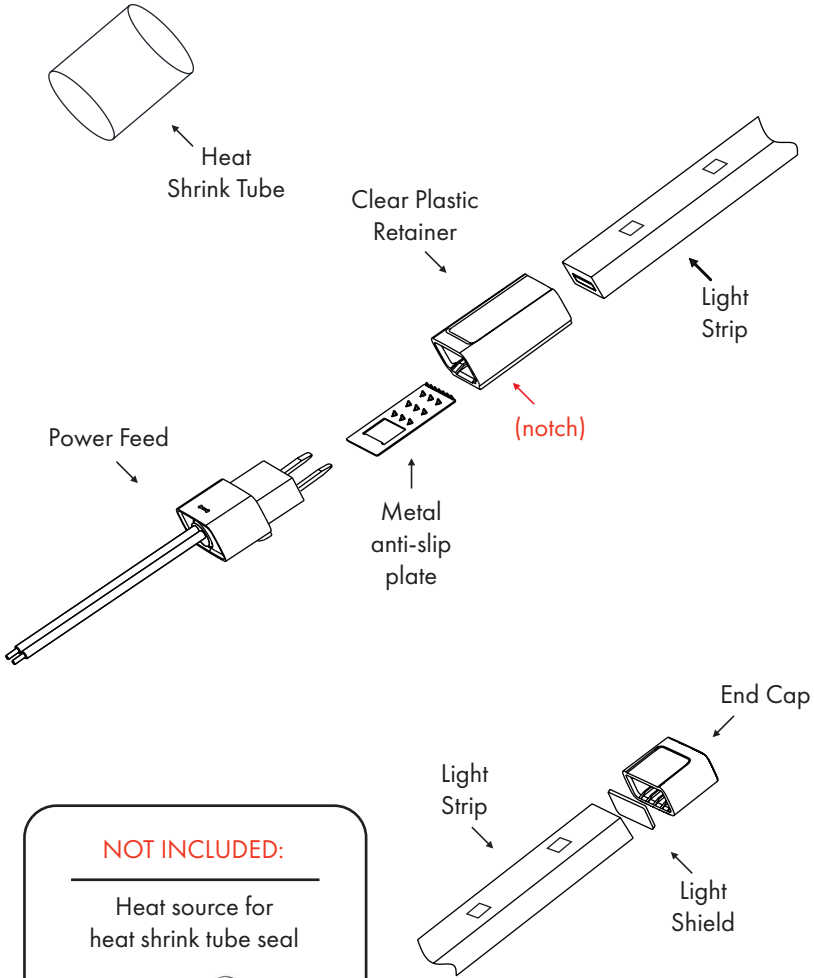

FIGURE B: Parts & Pieces



NOT INCLUDED:

Heat source for heat shrink tube seal



FIGURES

FIGURE C: Proper Handling

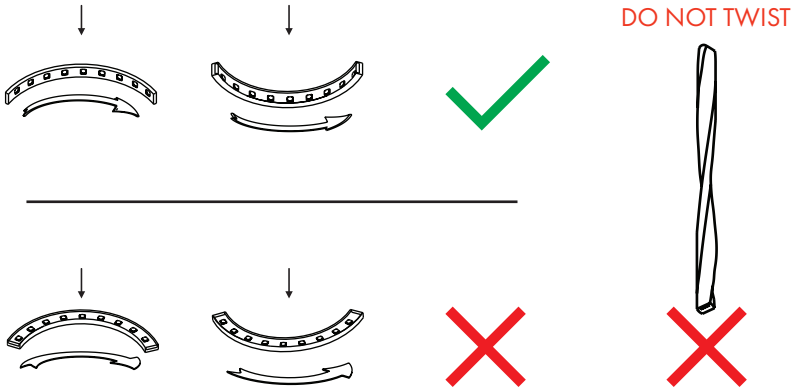

FIGURE D: Proper positioning of connector pins

