

# POLYETHYLENE VERTICAL TANKS

**- FOR GENERAL PURPOSE APPLICATIONS**

**PREMIER TANKS** are manufactured to the highest engineering standards, guaranteeing quality and reliability in every product.

- ★ Rugged – one piece – impact-resistant – UV stable.
- ★ CSA and ANSI/NSF 61 certified for drinking water.
- ★ Resistant to most chemicals (consult factory).
- ★ Light green, dark green or black color options.
- ★ 8 year warranty – fully recyclable.

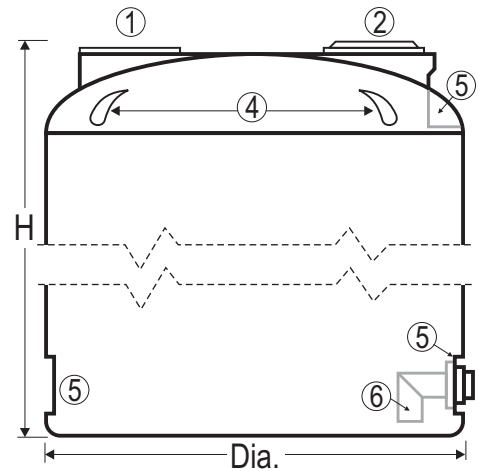

## SIZE SELECTION GUIDE

USA		CANADA		Dimensions
Model	US gal.	Model	Imp. gal.	
VU 130	130	VW 110	110	30" Dia. x 53"H
VU 300	300	VW 250	250	47" Dia. x 47"H
VU 480	480	VW 400	400	47" Dia. x 71"H
VU 575	575	VW 480	480	71" Dia. x 44"H
VU 625	625	VW 520	520	47" Dia. x 90"H
VU 795	795	VW 670	670	47" Dia. x 112"H
VU 960	960	VW 800	800	71" Dia. x 67"H
VU 1150	1150	VW 960	960	71" Dia. x 79"H
VU 1440	1440	VW 1200	1200	91" Dia. x 63"H
VU 1535	1535	VW 1280	1280	71" Dia. x 103"H
VU 2000	2000	VW 1660	1660	102" Dia. x 66"H
VU 2340	2340	VW 1950	1950	91" Dia. x 92"H
VU 3000	3000	VW 2500	2500	102" Dia. x 95"H
VU 4000	4000	VW 3330	3330	102" Dia. x 123"H
VU 4999	4999	VW 4160	4160	102" Dia. x 152"H

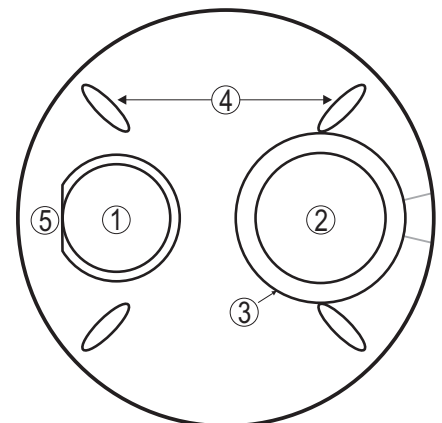

### FEATURES:

1. 17" dia. flat area for fill opening, agitators, instruments.
2. 16" dia. fill opening with self-venting lid.
3. Provision for 21" lid with self-venting lid.
4. Tie-down slots prevent slipping straps.
5. Flat areas provided for additional fittings.
6. 2" Plastic drain fitting with siphon tube.

*Note:* Additional fittings can be factory or field installed. Details may vary according to tank size.

**Look for the PREMIER label of quality. PREMIER PLASTICS ... Good Solid Tanks!**



**PREMIER  
PLASTICS INC.**

8328 River Way, Delta, BC, Canada V4G 1C4  
 Bus: (604) 952-6686 Fax: (604) 952-6696  
 Toll Free: 1-800-661-4473  
 E-mail: premier@ultranet.ca  
 www.premierplastics.com

Represented by: