

# IT'S LITTLE, BUT IT PACKS A BIG PUNCH.

## [ JET RITE BOOSTER TANK WITH STAINLESS STEEL NIPPLES ]

©2008 Flexcon Industries

16 gauge solid steel tank, finished with highest quality powder coat finish.

Condensation reducing design virtually eliminates external corrosion.

Stainless Steel Nipples designed to stand up to the harshest elements

Deep drawn domes for strength

Steel clench ring regulates movement and prevents diaphragm from rubbing against tank wall.



Jet Rite 2 tanks are ideally suited for irrigation applications, booster systems, shallow jet pumps and centrifugal pump configurations. The Jet Rite 2 series is constructed with a single FDA approved 100% butyl diaphragm and a polypropylene liner assembly that completely contains drawdown water keeping it as pure as possible.

In addition to their bullet proof design, Jet Rite 2 tanks are made with a stainless steel system connection. And, they are finished with appliance quality paint to help them withstand even the harshest outdoor elements. They are also available in both vertical and horizontal models providing unlimited installation flexibility.

If your looking for the highest quality booster tank, look no further, Jet Rite 2 will give you all the oomph you need and more.



**FLEXCON**  
**INDUSTRIES**  
The Reliable Source®



## MATERIALS OF CONSTRUCTION

- **Tank:** 16 gauge cold rolled steel
- **Finish:** Appliance quality paint for indoor or outdoor installation
- **Water chambers:** 100% butyl rubber, virgin polypropylene liner
- **Connection:** Stainless Steel
- **Testing:** High pressure, seam weld, helium, final precharge check
- **Air valve:** Brass valve with o-ring seal
- **Warranty:** Five year

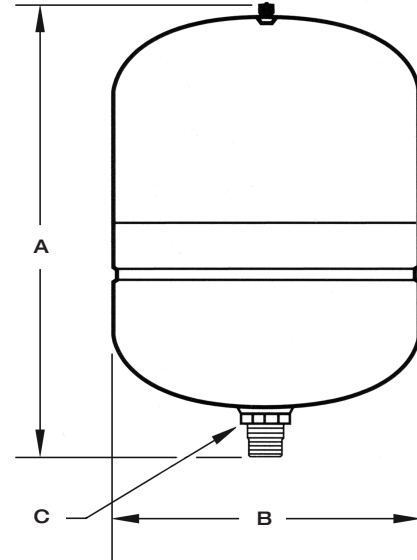

## DIMENSIONS & CAPACITIES - INLINE MODELS

Model	Total Tank Volume		A Height / Length		B Diameter		C Connection	Total Weight	
	gal	liters	in	cm	in	cm		lbs	kilos
PJR 6	2.1	8	12.0	30.0	8.0	20.0	.75" NPT	5.0	2.3
PJR 15	4.8	18	14.5	37.0	11.0	28.0	.75" NPT	10.0	4.6
PJR 25	9.0	32	18.9	48.1	12.5	31.8	.75" NPT	15.4	7.0
PJR 44IL	14.0	53	19.75	50.0	15.3	39.0	1" NPT	23.3	10.6

## DIMENSIONS & CAPACITIES - HORIZONTAL MODELS

PJR 20S	5.3	20	17.5	44.4	11.4	28.9	.75" NPT	13.3	6.0
PJR 25S	8.5	32	18.9	48.1	12.5	31.8	.75" NPT	15.4	7.0
PJR 44S	14.0	53	20.8	52.8	16.3	41.4	.75" NPT	27.0	12.3
PJR 66S	20.0	80	28.5	72.4	16.3	41.4	1" NPT	38.0	17.2

Maximum working pressure 125 psig. Maximum working temperature, internal & external 140° F. Tank pre-charge 20 psig.

## QUICK SIZING CHART

Model	Total Tank Volume		Total Drawdown*					
	gal	liters	20/40		30/50		40/60	
	gal	liters	gal	liters	gal	liters	gal	liters
PJR 6	2.1	8	0.8	2.9	0.7	2.5	0.6	2.1
PJR 15	4.8	18	1.7	6.6	1.5	5.6	1.3	4.8
PJR 20S	5.3	20	1.9	7.3	1.6	6.2	1.4	5.4
PJR 25 (S)	9.0	32	3.1	11.7	2.6	9.8	2.3	8.7
PJR 44 (S)	14.0	53	5.1	19.3	4.3	16.4	3.8	14.2
PJR 60S	20.0	80	7.6	28.8	6.5	24.8	5.5	20.8
PJR 44IL	14.0	53	5.1	19.3	4.3	16.4	3.8	14.2

\*Total drawdown assumes tank pre-charge set at 2 psi below cut-in pressure. Drawdown can be affected by many factors, including temperature, pressure, and elevation.

> [www.flexconind.com](http://www.flexconind.com)  
 > 781-986-2424  
 > 300 Pond Street  
 > Randolph, MA 02368

