

## Self-Priming FBSE 1/2 - 3 hp

**BOOK:** SPC-015  
**DATE:** Sep. 1, 2012

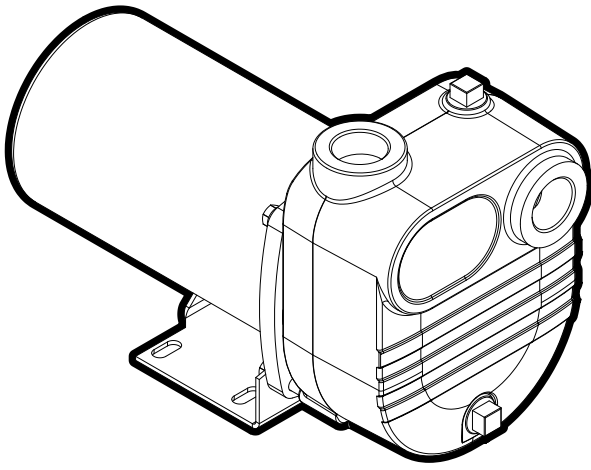

### Features:

- **Volute:** Cast iron rugged construction with tapped openings provided for priming, venting and draining.
- **Impeller:** Semi open cast iron, ideal for handling fertilizer, salt water, dirty water or other liquids. The impeller is blind hole tapped so the liquid will not corrode the shaft.
- **Seal:** Standard carbon/ceramic faces, Viton® elastomers, 300 series stainless components.
- **Motor:** Comes with a reliable industry standard motor. Motors range from 1/2 to 3 hp and use higher than NEMA service factor.

### Applications:

- Irrigation
- Construction
- Mining
- Commercial
- Municipal
- Light Industrial
- Residential

Viton® is a registered trademark of E. I. du Pont de Nemours and Company.

### Specifications:

**Capacities:** to 126 gpm

**Heads:** to 70 feet

**Working Pressure:** 75 psi max

**Temperature:** 120 °F max

**Rotation:** clockwise viewed from motor end

**Pipe Connections:** NPT

HP	Discharge	Suction
1/2 - 1	1-1/4"	1-1/4"
1-1/2 - 3	2"	2"

## Self-Priming FBSE 1/2 - 3 hp

### Dimensional Drawings:

FIGURE 1

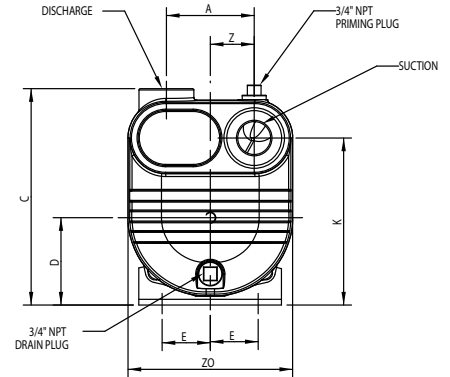
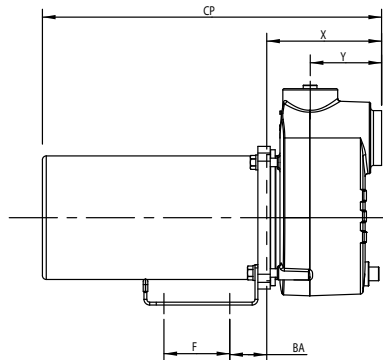
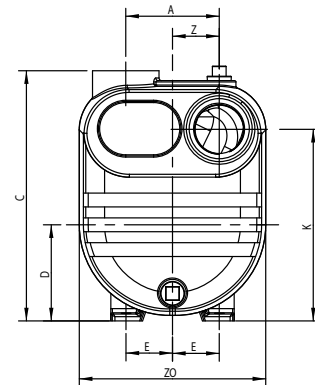
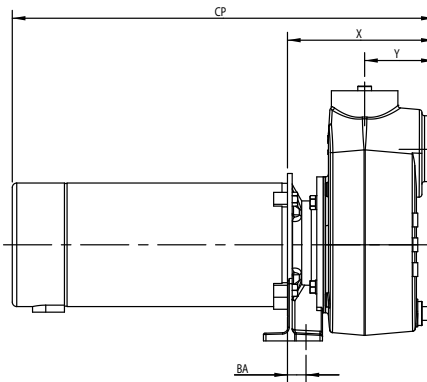

FIGURE 2  
FBSE-300-S  
FBSE-300-T



### Dimensions:

Model	Fig.	Suction	Discharge	CP	A	BA	C	D	E	F	K	X	Y	Z	ZO
FBSE-50-S	1	1-1/4	1-1/4	15.46	4.00	1.69	9.86	3.98	2.20	3.00	7.61	5.23	3.25	2.00	7.50
FBSE-75-S	1	1-1/4	1-1/4	15.96	4.00	1.69	9.86	3.98	2.20	3.00	7.61	5.23	3.25	2.00	7.50
FBSE-100-S	1	1-1/4	1-1/4	16.96	4.00	1.69	9.86	3.98	2.20	3.00	7.61	5.23	3.25	2.00	7.50
FBSE-150-S	1	2	2	17.91	4.26	1.69	11.00	3.98	2.20	3.00	8.36	5.44	3.17	2.13	8.50
FBSE-200-S	1	2	2	19.16	4.26	1.69	11.00	3.98	2.20	3.00	8.36	5.44	3.17	2.13	8.50
FBSE-300-S	2	2	2	19.23	4.26	.85	11.44	4.38	2.13	N/A	8.37	6.69	3.17	2.13	8.50
FBSE-300-T	2	2	2	20.43	4.26	.85	11.44	4.38	2.13	N/A	8.37	6.69	3.17	2.13	8.50

Note: Dimensions are for estimating purposes only. All dimensions in inches.

### Ordering Information:

#### Complete Pump

Model	HP	PH	Suction/Discharge	Order No.	Wt.
FBSE-50-S	1/2	1	1-1/4" x 1-1/4"	92931005	41
FBSE-75-S	3/4	1	1-1/4" x 1-1/4"	92931007	42
FBSE-100-S	1	1	1-1/4" x 1-1/4"	92931010	46
FBSE-150-S	1-1/2	1	2" x 2"	92931015	52
FBSE-200-S	2	1	2" x 2"	92931020	60
FBSE-300-S	3	1	2" x 2"	92931030	70
FBSE-300-T	3	3	2" x 2"	92933030	60

Notes: All dimensions in inches. All weight in pounds.

#### Pump End Kit

Model	HP	PH	Suction/Discharge	Order No.	Wt.
FBSE-50-K	1/2	PE	1-1/4" x 1-1/4"	92925005	18
FBSE-75-K	3/4		1-1/4" x 1-1/4"	92925007	18
FBSE-100-K	1		1-1/4" x 1-1/4"	92925010	18
FBSE-150-K	1-1/2		2" x 2"	92925015	18
FBSE-200-K	2		2" x 2"	92925020	22
FBSE-300-K	3		2" x 2"	92925030	25

Note: FBSE Pump End Kits (less motor) use 56J C face motors.

## Self-Priming FBSE 1/2 - 2 hp

### Exploded Parts Drawing:

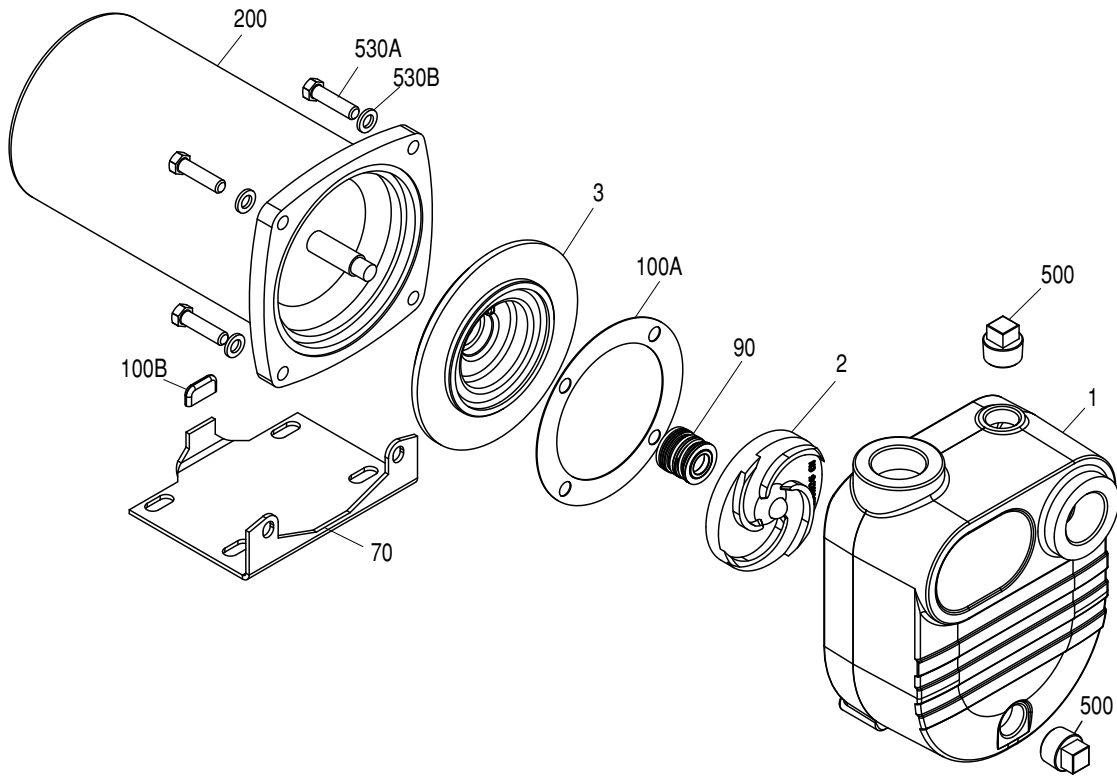

Fig. No.	Part Description	Part No.					Materials of Construction
		FBSE-50	FBSE-75	FBSE-100	FBSE-150	FBSE-200	
1	Pump Case	305461001			305461002		Cast Iron, ASTM-A48 CL30
2	Impeller	305461003	305461004	305461005	305461006	305461007	Cast Iron, ASTM-A48 CL30
3	Seal Plate	305461008			305461009		Cast Iron, ASTM-A48 CL30
70	Motor Base	305461010					CRS
90	Mechanical Shaft Seal	305463029					GL-SiC/GL-SiCxVITON®-SS
100A	Case Gasket	305463133			305463124		EPDM
100B	Base Protector	305463134					Vinyl
200	Motor (56-Z)	204073	204125	204154	204179	204186	Misc.
500	Pipe Plug 3/4" NPT (2-pack)	305463050					CAD Plated Steel
530A	Hex Bolt/Stud - Volute (4-pack)	305463135			305463136		Zinc Plated Steel
530B	Bracket Lockwasher	305463137			305463032		Zinc Plated Steel
530C	Bracket - Hex Nut	n/a			305463033		Zinc Plated Steel

Viton® is a registered trademark of E. I. du Pont de Nemours and Company.

## Self-Priming FBSE 3 hp

### Exploded Parts Drawing:

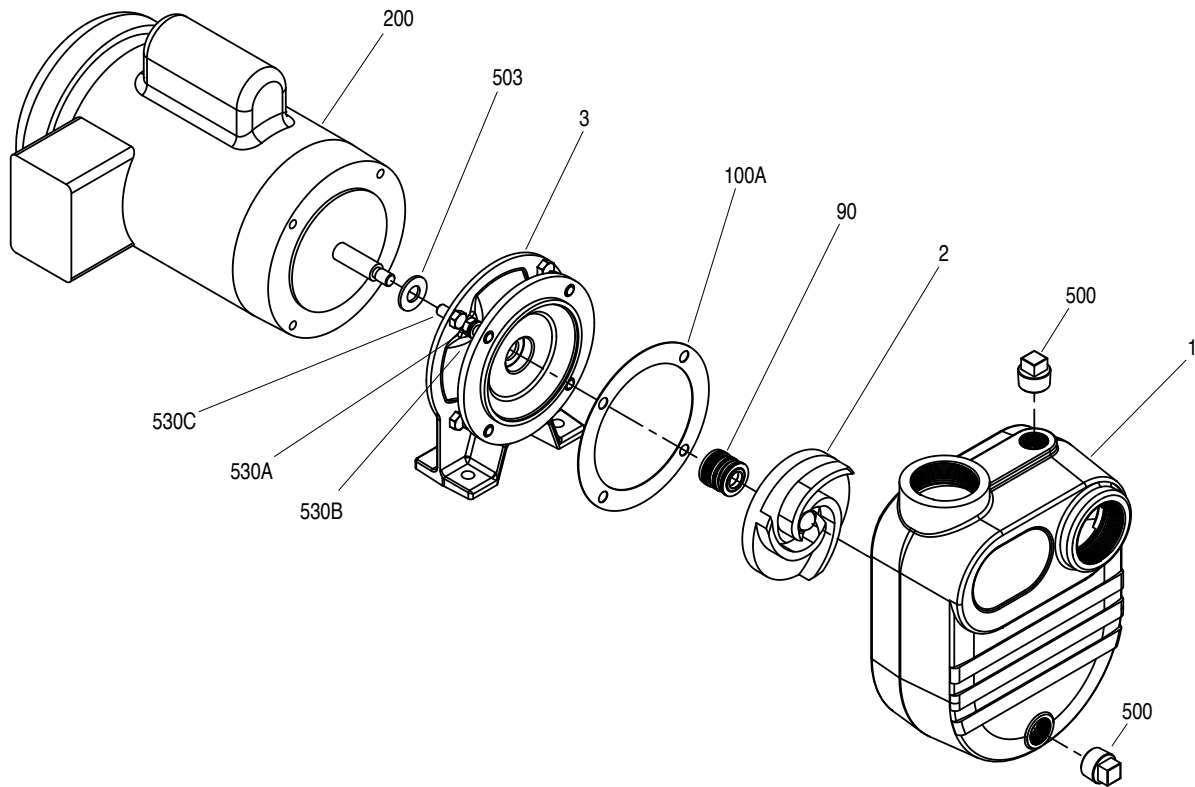

Fig. No.	Part Description	Part No.	Materials of Construction
		FBSE-300	
1	Pump Case	305715002	Cast Iron, ASTM-A48 CL30
2	Impeller	305453054	Cast Iron, ASTM-A48 CL30
3	Adaptor	305715008	Cast Iron, ASTM-A48 CL30
90	Mechanical Shaft Seal	305463029	GL-SiC/GL-SiCxVITON®-SS
100A	Case Gasket	305463124	EPDM
200	Motor (56-Z)	See Motor Selection	Misc.
500	Pipe Plug 3/4"NPT (2-pack)	305463050	CAD Plated Steel
503	Water Slinger	305463005	Neoprene
530A	Hex Bolt - Volute (4-pack)	305463030	Zinc Plated Steel
530B	Volute Flat Washer (4-pack)	305453006	Aluminum
530C	Hex Bolt - Bracket (4-pack)	305463030	Zinc Plated Steel

Viton® is a registered trademark of E. I. du Pont de Nemours and Company.

**Self-Priming FBSE 1/2 - 3 hp**

**Performance Curve:**

**3600 rpm**  
Nominal

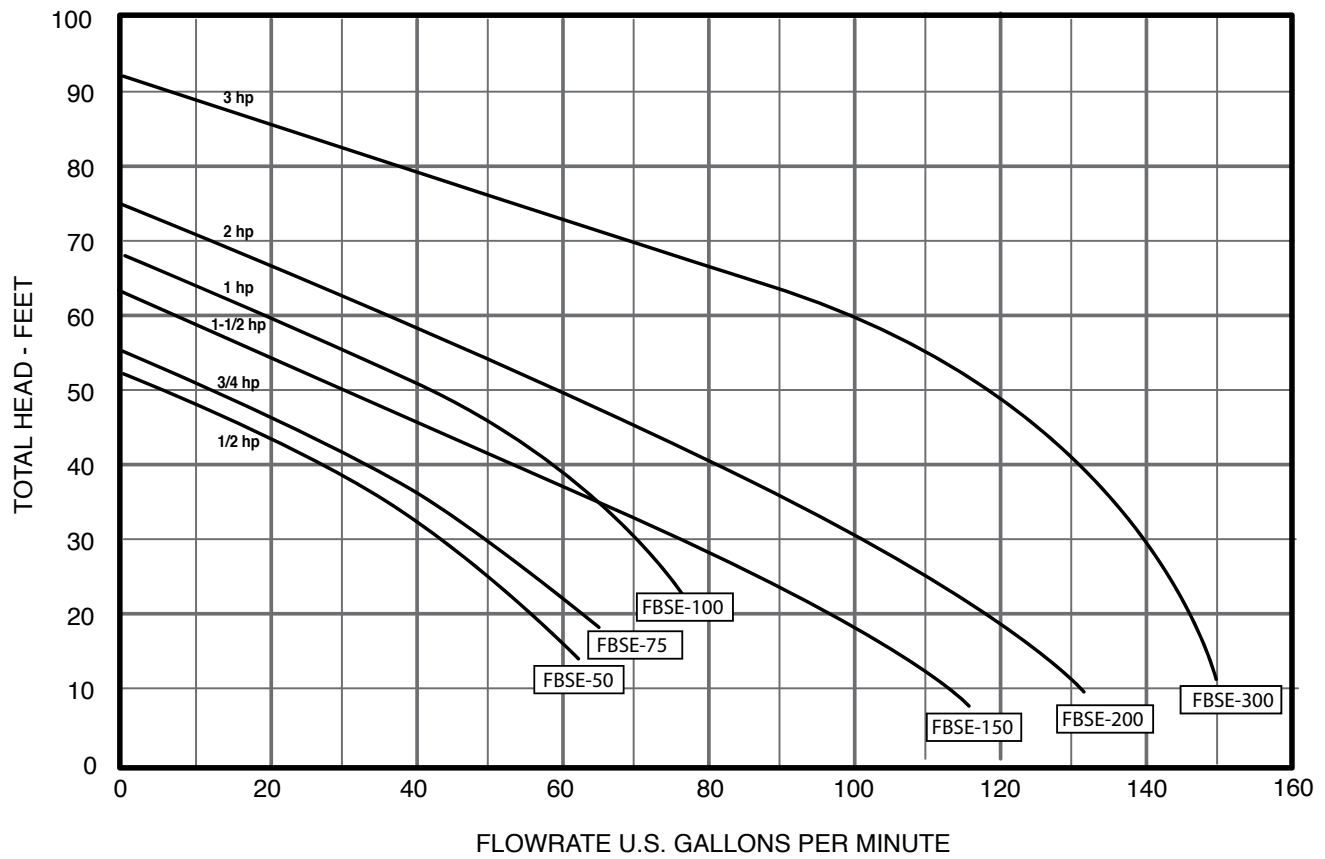







**Franklin Electric**

400 East Spring Street, Bluffton, Indiana 46714  
Tel: 260.824.2900 Fax: 260.824.2909  
[www.franklin-electric.com](http://www.franklin-electric.com)