

4" SUPER STAINLESS SUBMERSIBLE MOTORS

1/3 - 1.5 hp, 2 Wire: 1/3 - 3 hp 3 Wire, Single- & Three-Phase

Application Data:

These motors are built for dependable operation in 4" diameter or larger water wells. Continuous rating in 86 °F (30 °C) water.

For further information, refer to Franklin Electric's "Submersible Motors: Application, Installation, Maintenance Manual."

Special Features:

- No flow inducer sleeve required in water up to 86 °F (30 °C) for motors through 2 hp.
- Two-wire motors are split-phase designs with integral starting components and on-winding thermal overload protection, and do not require a control box. They feature Franklin's patented 2-wire BIAC starting switch which provides reverse impact torque to aid starting in adverse environments.
- Three-wire 60 Hz motors 1/3 - 1 hp use Franklin's exclusive 3-wire QD (Quick-Disconnect) Control Box with the patented QD Relay. This relay provides the ultimate in operational life.

Basic Features:

- Corrosion-Resistant All Stainless Steel Exterior Construction
- Stainless Steel Splined Shaft
- Hermetically-Sealed Windings
- Anti-Track Self-Healing Resin System
- Water Lubrication
- Filter Check Valve
- Kingsbury-Type Thrust Bearing
- Pressure Equalizing Diaphragm
- Built-In Lightning Arrestors (all single-phase; 200 and 230 Volt three-phase)
- Removable "Water-Bloc" lead installed in North American 60 Hz water well motors. Consult factory for additional leads.
- UL 778 Recognized (North American Voltages)
- CSA Certified
- ANSI/NSF 61 Certified
- NEMA Mounting Dimensions
- Rotation: single-phase - CCW; three-phase electrically reversible

WARNING: Serious or fatal electrical shock or fire hazard may result from failure to follow the instructions for proper installation and use which accompany this equipment. Do not use motor in swimming areas.

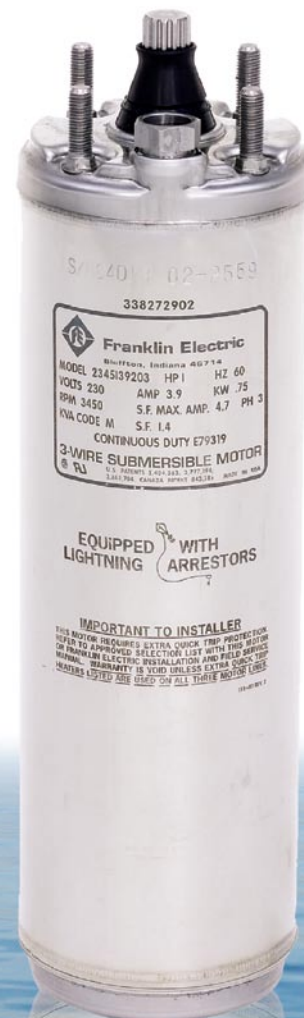

Availability

Single-Phase

2-Wire, Split-Phase, 60 Hz, 3450 rpm

HP	KW	VOLTS	"L" DIM		
			INS	LBS	KGS
1/3	0.25	115 OR 230	8.78	16	7.2
1/2	0.37	115 OR 230	9.53	18	8.1
3/4	0.55	230	10.66	21	9.5
1	0.75	230	11.75	24	10.9
1.5	1.1	230	15.12	31	14.1

2-Wire, Split-Phase, 50 Hz, 2875 rpm

HP	KW	VOLTS	"L" DIM		
			INS	LBS	KGS
1/2	0.37	220	9.53	18	8.1
3/4	0.55	220	10.66	21	9.5
1	0.75	220	11.75	24	10.9
1.5	1.1	220	15.12	31	14.1

3-Wire, Capacitor Start, 60 Hz, 3450 rpm^①

HP	KW	VOLTS	"L" DIM		
			INS	LBS	KGS
1/3	0.25	115 OR 230	8.78	17	7.7
1/2	0.37	115 OR 230	9.53	19	8.6
3/4	0.55	230	10.66	21	9.5
1	0.75	230	11.75	24	10.9
1.5	1.1	230	13.62	28	12.7
2	1.5	230	15.12	33	15.0
3	2.2	230	19.06	41	18.6

3-Wire, Capacitor Start, 50 Hz, 2875 rpm^①

HP	KW	VOLTS	"L" DIM		
			INS	LBS	KGS
1/3	0.25	220	8.78	17	7.7
1/2	0.37	220	9.53	19	8.6
3/4	0.55	220	10.66	21	9.5
1	0.75	220	11.75	24	10.9
1.5	1.1	220	13.62	28	12.7
2	1.5	220	15.12	33	15.0
3	2.2	220	19.06	41	18.6

Three-Phase

200, 230, 380, 460, 575 Volt-60 Hz; 220, 380 Volt-50 Hz

Consult factory for dimensional and weight data.

Construction Materials

Components	Standard Water Well
Casting	304 SS Over Iron
Stator Shell	301 SS
Shaft Extension	17-4 SS
Fasteners	305 SS or 302 SS
Seal Cover	Acetal
Seal	Nitrile Rubber Lip
Diaphragm	Nitrile Rubber
Diaphragm Cover	301 SS
Slinger	Nitrile Rubber
Lead Wire (or Cable)	XLPE ^②
Lead Potting	Epoxy
Lead Jam Nut	303 SS

① Franklin Electric control box required.

② Removable type installed in North American 60 Hz rated water well motors. Consult factory for additional leads.

Specifications subject to change without notice. Contact Franklin Electric if material types are required for bid specifications.

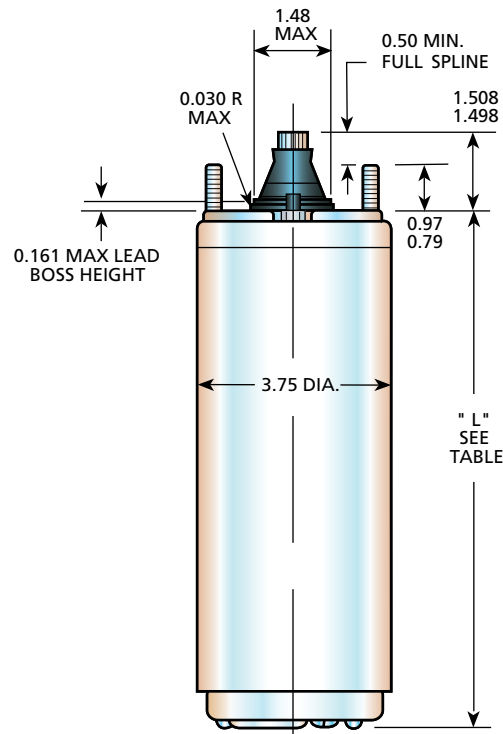

Franklin Electric

400 East Spring Street, Bluffton, Indiana 46714 • Tel: 260.824.2900 Fax: 260.824.2909 • www.franklin-electric.com