

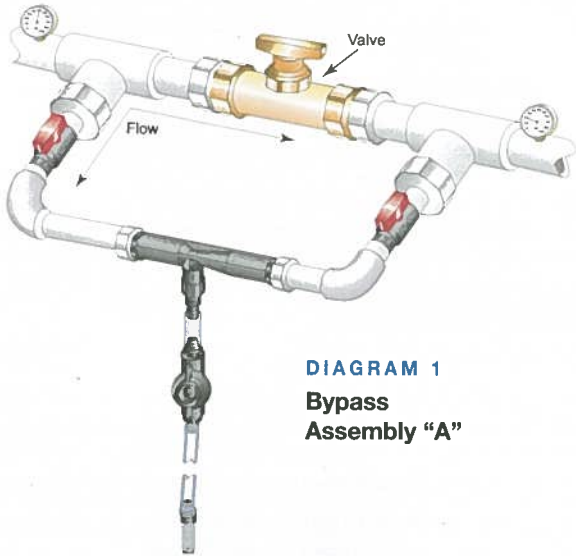

World Leader in Mixing and Contacting Technologies

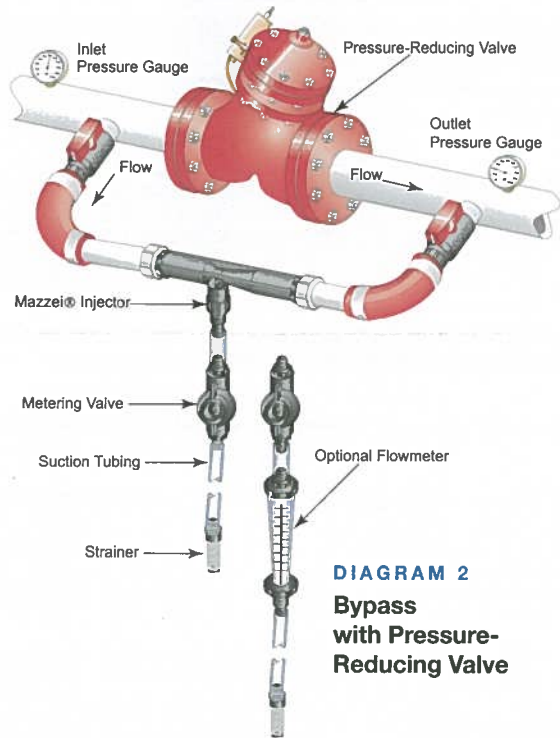

**DIAGRAM 1**  
Bypass  
Assembly "A"



**DIAGRAM 2**  
Bypass  
with Pressure-  
Reducing Valve

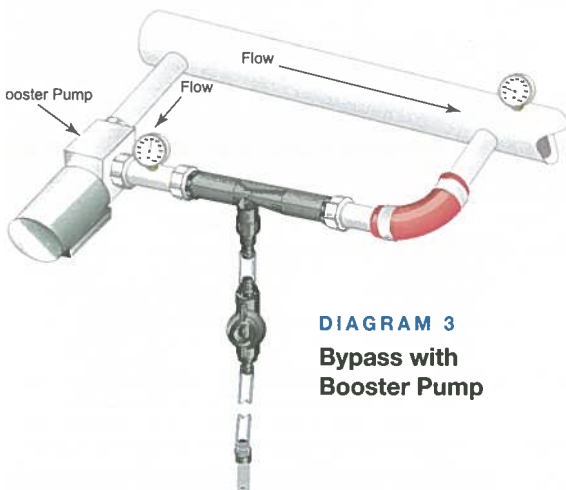
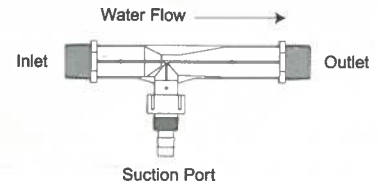

**DIAGRAM 3**  
Bypass with  
Booster Pump

## INSTALLATION NOTES FOR MAZZEI® INJECTORS

Factors which allow for reliable Mazzei® injector operation are noted as follows:

- Mazzei® injectors require differential pressure to create suction. The injector's outlet pressure (backpressure) must be sufficiently lower than the inlet pressure. For most models, significant suction begins with a 25-30% pressure differential.
- Mazzei® injectors should be installed with the main body in a horizontal position, or with the outlet facing up. The injector suction port can be oriented in any position.
- To insure consistent suction, the outlet side of the injector should be flooded or have some restriction downstream (backpressure).
- Always use full flow isolation valves and non-restrictive fittings when connecting to the injector. These valves and fittings should be at least the same size as the inlet/outlet connections on the injector. Isolation valves are optional, but recommended.
- Do not over-tighten the injector when attaching piping and fittings. The use of an appropriate thread sealant is recommended.
- Install pressure gauges near the inlet and outlet of the injector to monitor operating conditions.



## Typical Installations

The injector is installed around a point of restriction, such as a regulator valve or a gate/ball valve. These create a differential pressure across the injector, thereby allowing the injector to produce a vacuum and draw in material. (DIAGRAMS 1+2)

When mainline pressure cannot be reduced, a small booster pump can be used to create a sufficient differential to operate the injector. (DIAGRAM 3)

For additional information, including troubleshooting tips and injector performance data, please visit our website at [www.mazzei.net](http://www.mazzei.net). Always follow environmental regulations regarding backflow prevention and chemical use.