

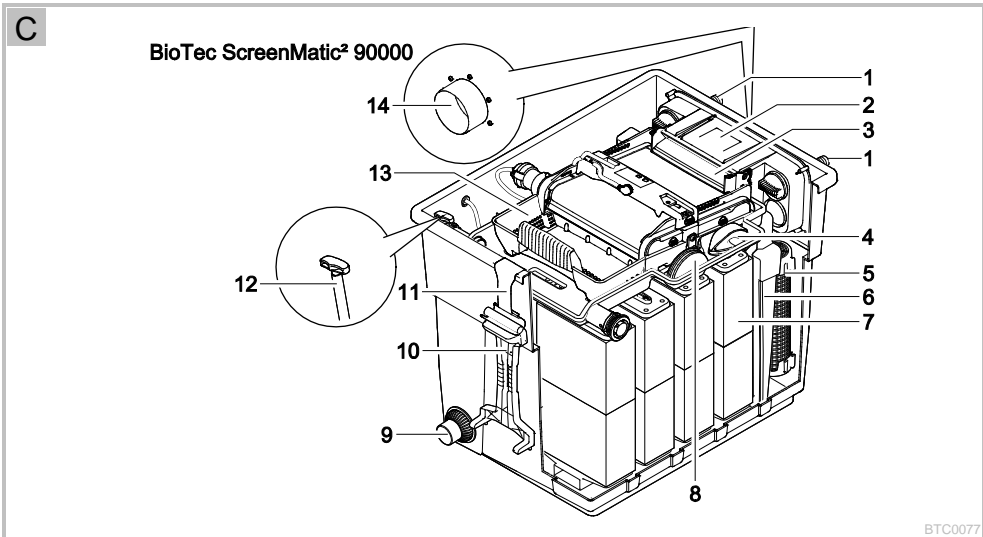

BioTec ScreenMatic²

DE	Gebrauchsanleitung
EN	Operating instructions
FR	Notice d'emploi
NL	Gebruiksaanwijzing
ES	Instrucciones de uso
PT	Instruções de uso
IT	Istruzioni d'uso
DA	Brugsanvisning
NO	Bruksanvisning
SV	Bruksanvisning
FI	Käyttöohje
HU	Használati útmutató
PL	Instrukcja użytkowania
CS	Návod k použití
SK	Návod na použitie
SL	Navodila za uporabo
HR	Uputa o upotrebi
RO	Instrucțiuni de folosință
BG	Упътване за употреба
UK	Посібник з експлуатації
RU	Руководство по эксплуатации
CN	使用说明书

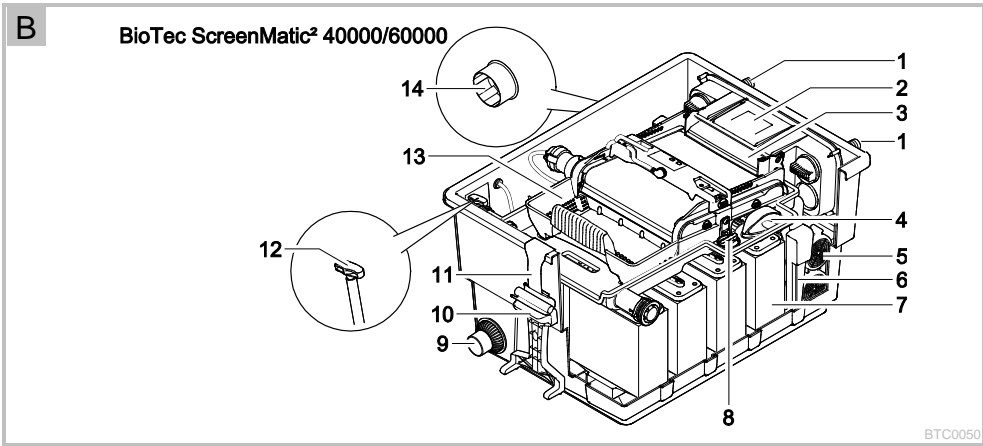

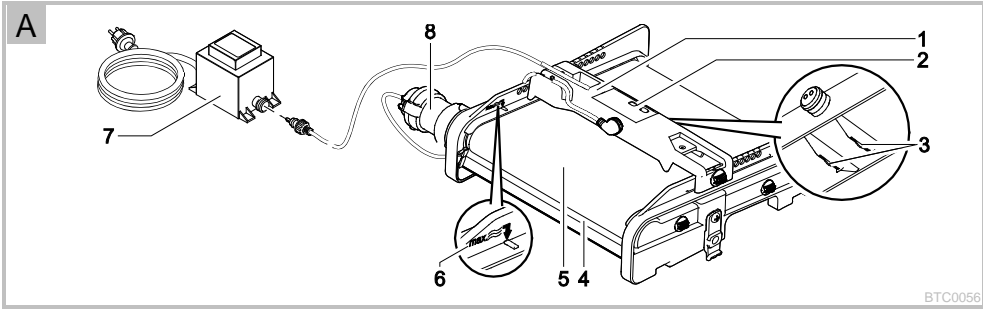



D

BioTec ScreenMatic² 140000

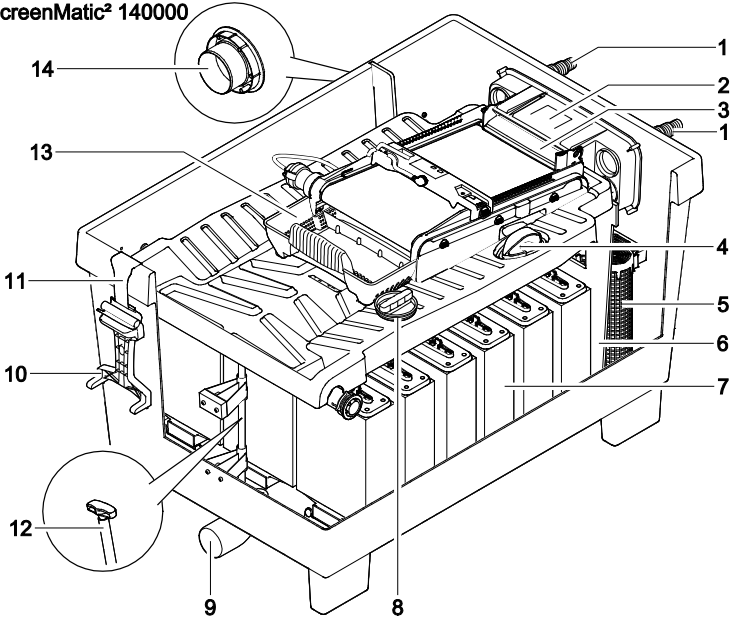

BTC0049

E

BioTec ScreenMatic² 40000/60000/90000

BioTec ScreenMatic² 140000

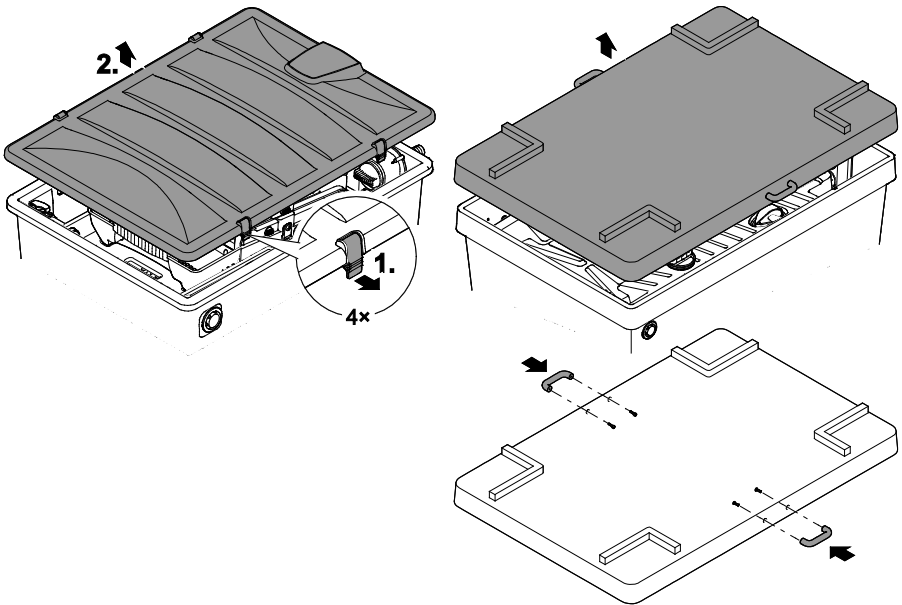

BTC0051



F

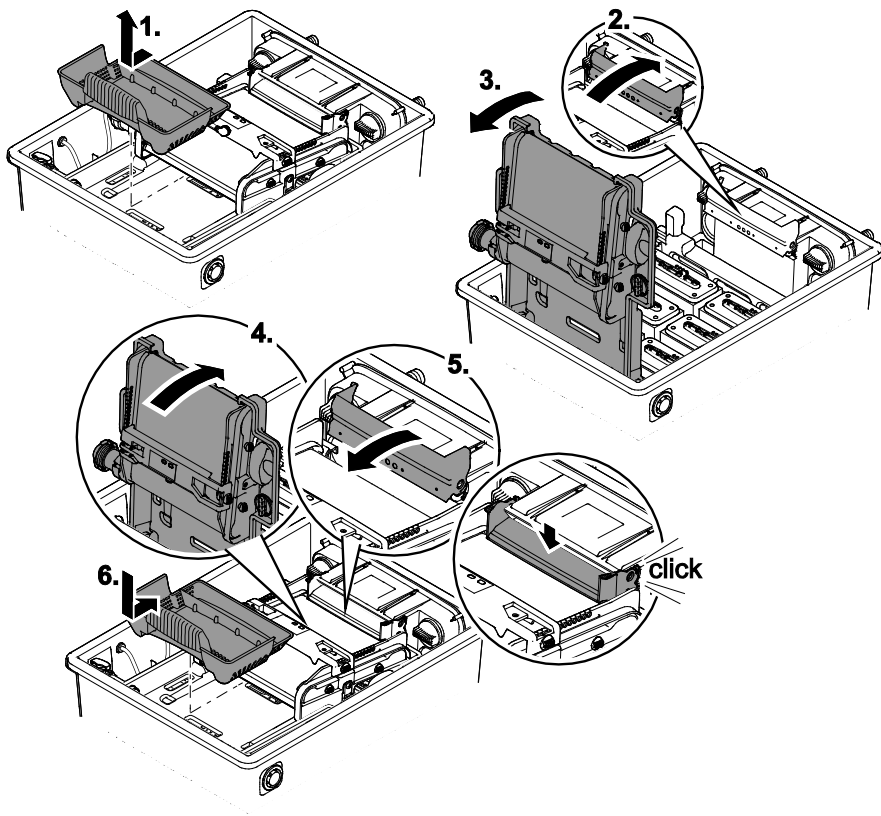

BTC0052



G

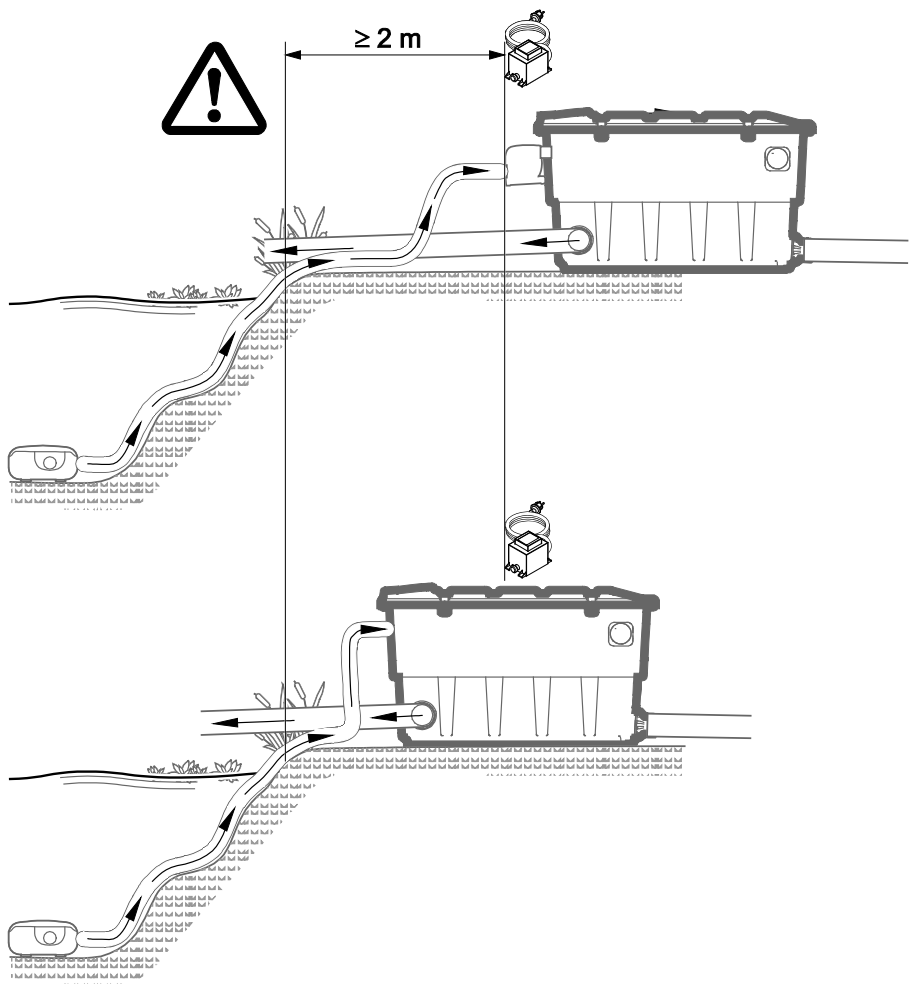

BTC0048



H

BioTec ScreenMatic² 40000/60000

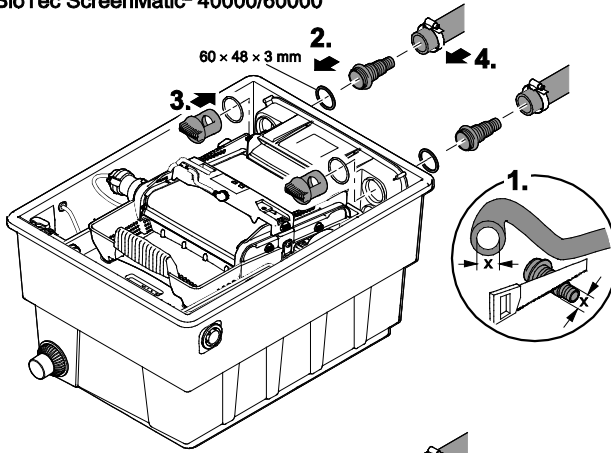

BioTec ScreenMatic² 90000

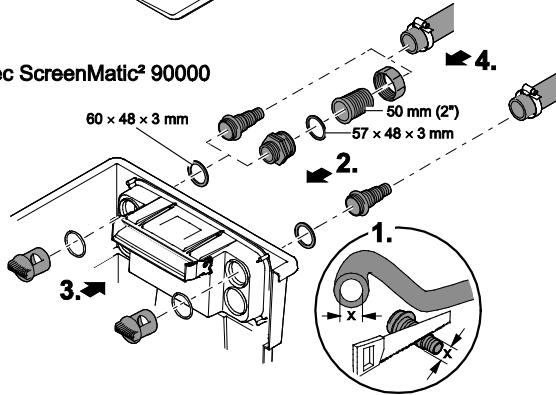

BioTec ScreenMatic² 140000

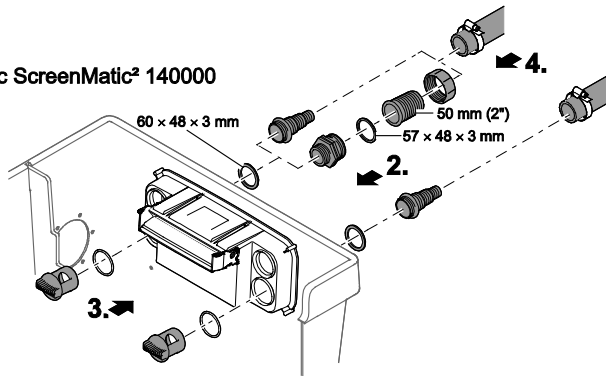

BTC0058

I

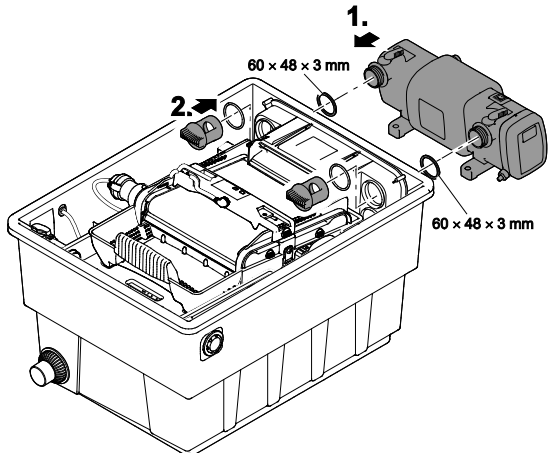

BTC0059

J

BioTec ScreenMatic² 140000

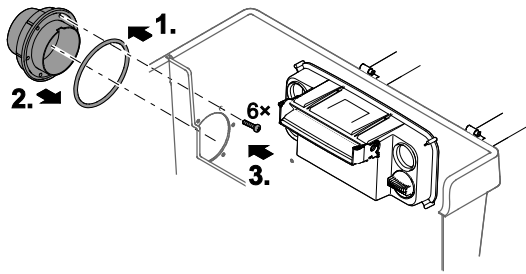

BTC0064



K

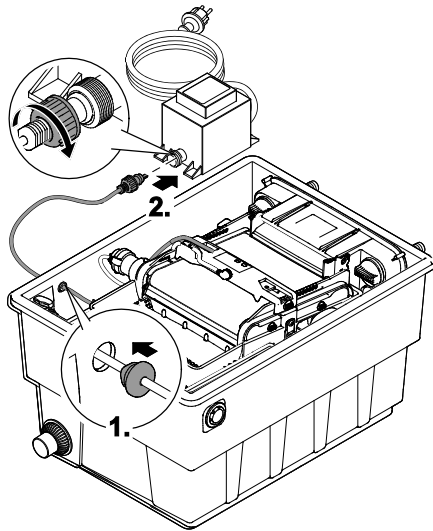

BTC0061

L

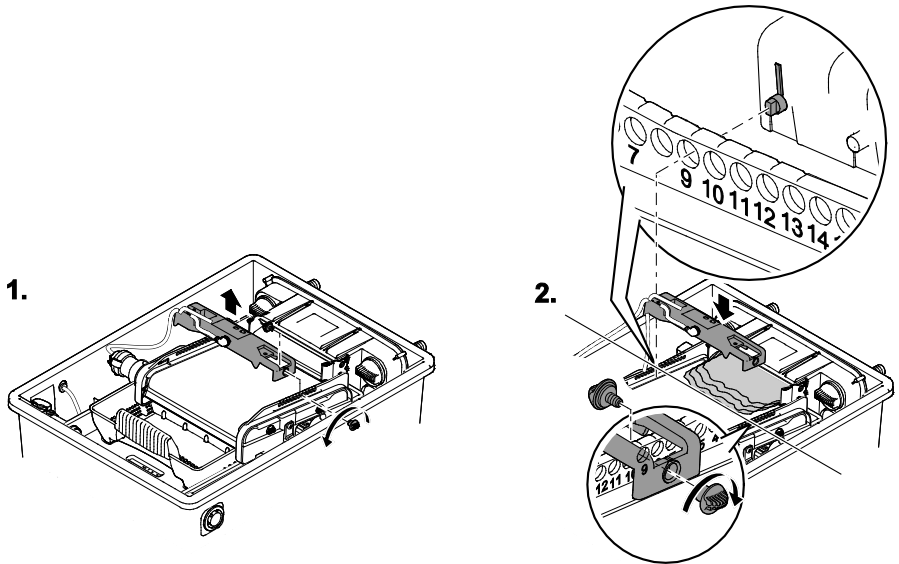

BTC0062

M

BioTec ScreenMatic² 40000/60000

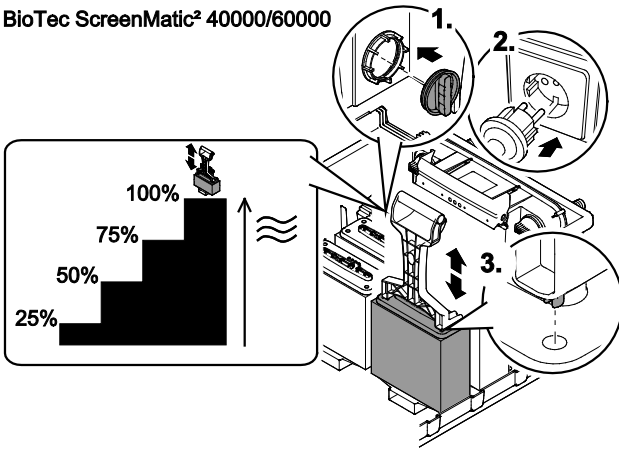

BTC0053

N

BioTec ScreenMatic² 90000

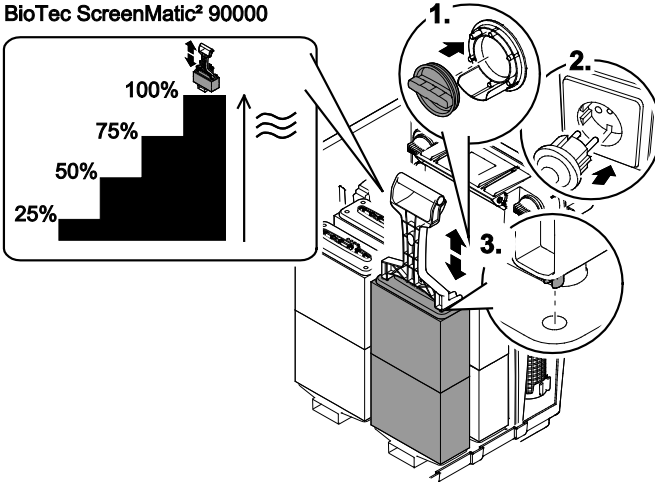

BTC0082



O

BioTec ScreenMatic² 140000

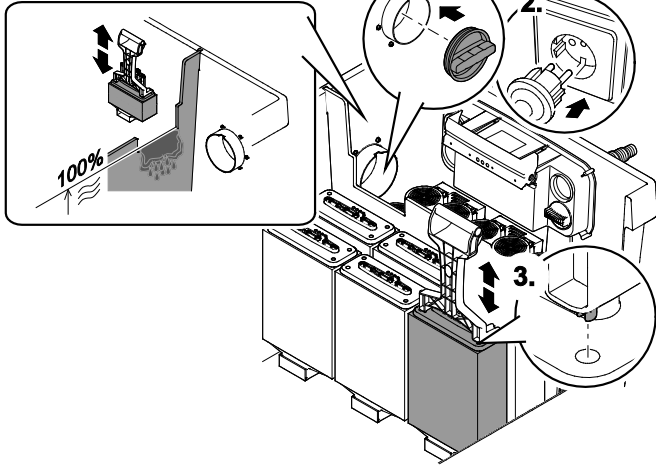

BTC0079

P

BioTec ScreenMatic² 40000/60000

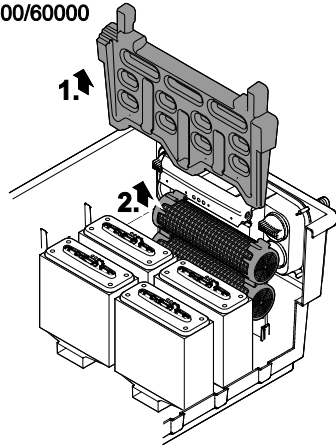

BTC0055



S

1.

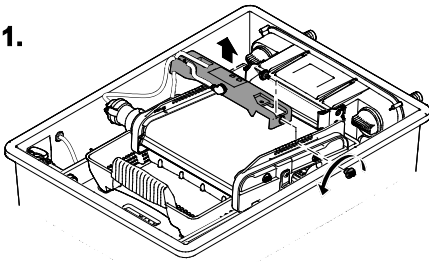

BioTec ScreenMatic² 40000/60000/90000

2.

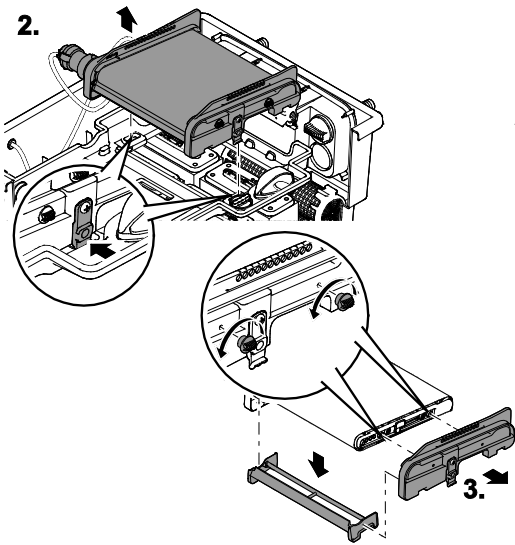

BioTec ScreenMatic² 140000

2.

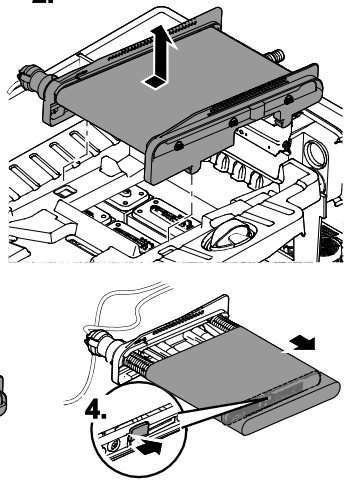

BTC0060

T

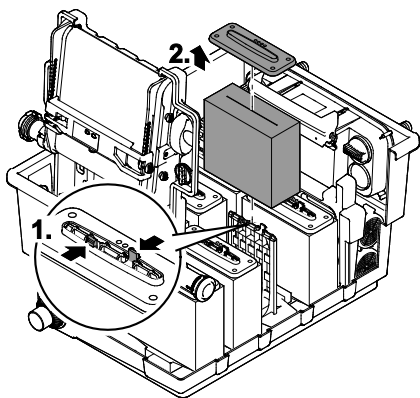

BTC0054

Table of Contents

1	Safety information	29
1.1	Electrical connection	29
1.2	Safe operation	29
2	Information about this operating manual	30
2.1	Symbols used in these instructions	30
2.1.1	Warnings	30
2.1.2	Additional information	30
3	Product Description	31
3.1	Unit configuration	31
3.2	Properties	31
3.3	Intended use	31
3.4	Possible incorrect use	31
3.5	Accessing the unit	32
3.5.1	Opening the container	32
3.5.2	Hinging the screen holder up/down	32
4	Installation and connection	32
4.1	Installation planning	32
4.2	Connecting the inlet	33
4.3	Connecting a UVC clarifier	33
4.4	Connecting the outlet	33
4.5	Connecting the dirt outlet	34
4.6	Carry out the electrical connection	34
5	Commissioning/start-up	35
5.1	Biological filter starter	35
5.2	Order of starting up steps	35
5.3	Aligning the control device	35
6	Operation	36
6.1	Operating panel	36
6.2	Manual cleaning	36
6.3	Automatic cleaning	37
6.4	Time-dependent cleaning	37
6.5	System messages	37
7	Remedy of faults	38
8	Maintenance and cleaning	38
8.1	Regular cleaning work	38
8.2	Cleaning foam filters	39
8.3	Cleaning/replacing the substrate tubes	39
8.4	Cleaning/replacing the ScreenMatic screen	40
8.5	Replacing foam filters	40
9	Storage/overwintering	41
10	Wear parts	41
11	Disposal	41
12	Technical data	42
13	Spare parts	42

WARNING

- This unit can be used by children aged 8 and above and by persons with reduced physical, sensory or mental capabilities or lack of experience and knowledge if they are supervised or have been instructed on how to use the unit in a safe way and they understand the hazards involved.
- Do not allow children to play with the unit.
- Only allow children to carry out cleaning and user maintenance under supervision.
- Ensure that the unit is fused for a rated fault current of max. 30 mA by means of a fault current protection device.
- Only connect the unit if the electrical data of the unit and the power supply correspond. The unit data is to be found on the unit type plate, on the packaging or in this manual.
- Possible death or severe injury from electrocution! Before reaching into the water, always disconnect all units in the water that have a voltage of >12 V AC or >30 V DC from the power supply.
- Only operate the unit if no persons are in the water.

1 Safety information

1.1 Electrical connection

- Electrical installations must meet the national regulations and may only be carried out by a qualified electrician.
- A person is regarded as a qualified electrician if, due to his/her vocational education, knowledge and experience, he or she is capable of and authorised to judge and carry out the work commissioned to him/her. This also includes the recognition of possible hazards and the adherence to the pertinent regional and national standards, rules and regulations.
- For your own safety, please consult a qualified electrician.
- Extension cables and power distributors (e.g. outlet strips) must be suitable for outdoor use (splash-proof).
- Protect the plug connection from moisture.
- Only connect the unit to a correctly fitted socket.

1.2 Safe operation

- Never operate the unit if an electrical cable is defective!
- Never operate the unit if the housing is defective!
- Never carry or pull the unit by the electrical cable.
- Route cables such that they are protected from damage and do not present a tripping hazard.
- Only open the unit housing or its attendant components if this is explicitly specified in the operating instructions.
- Only use original spare parts and accessories for the unit.
- Never carry out technical changes to the unit.

2 Information about this operating manual

Welcome to OASE Living Water. You made a good choice with the purchase of this product **BioTec Screen-Matic² 40000/60000/140000**.

Prior to commissioning the unit, please read the instructions of use carefully and fully familiarise yourself with the unit. Ensure that all work on and with this unit is only carried out in accordance with these instructions.

Adhere to the safety information for the correct and safe use of the unit.

Keep these instructions in a safe place! Please also hand over the instructions when passing the unit on to a new owner.

2.1 Symbols used in these instructions

2.1.1 Warnings

The warning information is categorised by signal words, which indicate the extent of the hazard.



WARNING

- Indicates a possibly hazardous situation.
- Non-observance may lead to death or serious injuries.



NOTE

Information for the purpose of clarification or for preventing possible damage to assets or to the environment.

2.1.2 Additional information

□ A Reference to a figure, e.g. Fig. A.

→ Reference to another section.

3 Product Description

3.1 Unit configuration

<input type="checkbox"/> A	ScreenMatic rotating screen unit
1	Control device
2	Operating panel
3	Sensor underneath the control device <ul style="list-style-type: none"> • When the sensor comes into contact with the water on the ScreenMatic screen, an automatic cleaning process is triggered.
4	Stripper <ul style="list-style-type: none"> • scrapes the debris from the ScreenMatic screen and conveys it into the debris tray.
5	ScreenMatic screen
6	"Max. water jet" mark <ul style="list-style-type: none"> • Debris may be washed out of the debris collection tray if the water jet from the water distributor exceeds this mark.
7	Transformer <ul style="list-style-type: none"> • Voltage supply for the control device and motor
8	Motor <ul style="list-style-type: none"> • Drive of the ScreenMatic rotating screen unit

<input type="checkbox"/> B, C, D	BioTec ScreenMatic² 40000/60000/140000
1	Inlets, 2 x
2	Water distributor
3	Distributor extension
4	Brush for regularly cleaning the ScreenMatic screen
5	Substrate tube <ul style="list-style-type: none"> • BioTec ScreenMatic² 40000: 2 x • BioTec ScreenMatic² 60000: 3 x • BioTec ScreenMatic² 90000: 4 x • BioTec ScreenMatic² 140000: 12 x
6	Separating plate <ul style="list-style-type: none"> • can be removed from the BioTec ScreenMatic² 40000/60000/90000 for maintenance purposes.
7	Foam filter <ul style="list-style-type: none"> • BioTec ScreenMatic² 40000/60000: 8 x • BioTec ScreenMatic² 90000: 16 x • BioTec ScreenMatic² 140000: 18 x
8	Blind plug for closing the outlet (14) <ul style="list-style-type: none"> • Closing the outlet before cleaning the foam filters prevents dirty water from flowing back into the pond.
9	Dirt outlet
10	Foam cleaning device
11	Holder for the foam cleaning device
12	Dirt outlet slide valve
13	Debris tray
14	Outlet

3.2 Properties

- High performance flow-through filter for ponds up to 40 m³, 60 m³, 90 m³ or 140 m³.
- Electrically driven ScreenMatic rotating screen for automatic removal of coarse debris.
- Low-maintenance filter due to the automatic removal of coarse debris.
- Bottom dirt outlet with slide valve for removal of dirt/debris from the filter system.
- Convenient cleaning of the foam filters directly inside the filter.
- Foam cleaning device and holder for fastening the foam cleaning device to the container.
- Perfectly tailored to the OASE AquaMax Eco filter pumps.
- Direct connection of the OASE UVC clarifiers of the Vitronic 18W/24W/36W, Bitron C and Bitron Eco series possible.
- Use of different filter media to ensure optimum colonisation of bacteria for biological filtration.

3.3 Intended use

BioTec ScreenMatic² 40000/60000/140000, referred to as "unit", may only be used as specified in the following:

- For cleaning garden ponds.
- Operation under observance of the technical data.

3.4 Possible incorrect use

The following restrictions apply to the unit:

- Only operate with water at a water temperature of +4 °C to +35 °C.

- Never use the unit to convey fluids other than water.
- Do not use for commercial or industrial purposes.
- Not suitable for salt water.
- Do not use in conjunction with chemicals, foodstuff, easily flammable or explosive substances.

3.5 Accessing the unit

- Remove the container cover: Access to the control device.
- Hinge up the screen holder: Access to the foam filters, substrate tubes, separating plate and outlet.

3.5.1 Opening the container

E

- BioTec ScreenMatic² 40000/60000: Release the locking clips, lift up the cover and remove.
- BioTec ScreenMatic² 140000: Lift the cover using the handles and remove.
 - Screw the handles onto the cover. The handles are not fitted on delivery.



NOTE

Only operate the unit with the container cover in place.

3.5.2 Hinging the screen holder up/down

How to proceed:

F

To hinge up/open

1. Remove the debris tray.
2. Hinge up the distributor extension.
3. Hinge up the screen holder with the ScreenMatic rotating screen unit.

To hinge down/close

4. Carefully hinge down the screen holder.
5. Push the distribution extension down until it audibly engages.
6. Replace the debris tray.

4 Installation and connection

4.1 Installation planning

G



WARNING

Dangerous electrical voltage.

Possible consequences: Death or severe injuries caused by electric shock from electrical units operated in or near water.

Protective measures for accessible ponds:

- Only use electrical units or installations with a rated voltage of $U_{AC} \leq 12 \text{ V}$ or $U_{DC} \leq 30 \text{ V}$ in the water.
- Electrical installations with a rated voltage of $U_{AC} > 12 \text{ V}$ or $U_{DC} > 30 \text{ V}$ must be located at a distance of at least 2 m from the water.

Protective measures for non-accessible ponds:

- Electrical installations with a rated voltage of $U_{AC} > 12 \text{ V}$ or $U_{DC} > 30 \text{ V}$ must be located at a distance of at least 2 m from the water.



NOTE

Use suitable transport and lifting aids to transport and install the unit.

The unit weighs more than 25 kg. (→ Technical data)

Distance from the pond

Electrical components of the filter system operate with a rated voltage of $U_{DC} = 12\text{ V}$. The supply voltage is supplied via an external transformer connected to the mains.

- Filter system with UVC clarifier fitted:
 - The filter system and transformer must be located at a distance of at least 2 m from the water.
- Filter system without UVC clarifier fitted:
 - The filter system can be installed directly next to the water. The transformer must be located at a distance of at least 2 m from the water.

Optimum ambient and operating conditions

Optimum operating results can be obtained with careful planning, taking the ambient conditions into account.

- As the filter is very heavy when filled, it must be placed on a suitable base (at least on slabs, but preferably on a poured concrete base) to prevent it from subsiding.
- Align the base slab horizontally.
- Ensure sufficient room for movement for carrying out cleaning and maintenance work.
- Allow the dirty water to drain out into a drain or far enough away from the pond to ensure that it cannot flow back into the pond.
- Do not position the inlet into the pond higher than the outlet of the filter system (e.g. above a water course or waterfall).



NOTE

A water course or waterfall guarantees optimum water return to the pond.

In this way, the filtered pond water is enriched with oxygen before it is returned to the pond.

4.2 Connecting the inlet

The filter system has two inlets with stepped hose adapters.

- For connecting a filter pump
- For connecting a UVC clarifier (→ Connecting a UVC clarifier)
- If an inlet is not used, fit a closed stepped hose adapter.
 - The stepped hose adapters are delivered closed.

Prerequisite:

- The container is open. (→ Opening the container)
- The screen holder is hinged up. (→ Hinging the screen holder up/down)

How to proceed:

H

1. Shorten the stepped hose adapter to the diameter of the hose used.
 - This reduces pressure losses.
2. Insert the stepped hose adapter with flat seal into the inlet opening.
3. Screw the distributor nut with O ring onto the stepped hose adapter and hand tighten.
 - BioTec ScreenMatic² 140000: Alternatively fit a 50 mm (2") hose connector.
4. Slip the hose clip over the hose, fit the hose onto the hose connector and secure with the hose clip.

4.3 Connecting a UVC clarifier

Prerequisite:

- The container is open. (→ Opening the container)
- The screen holder is hinged up. (→ Hinging the screen holder up/down)

How to proceed:

I

1. Fit the UVC clarifier with flat seal into the inlet opening.
2. Screw the distributor nut with O ring onto the stepped hose adapter and hand tighten.
 - Read the UVC clarifier operating instructions.

4.4 Connecting the outlet

- Use suitable pipes.
- Do not use any right-angled bends. Bends with a maximum angle of 45° are very efficient.

- Standing water in pipes can freeze when there is a hard frost and cause pipes to burst. For this reason, lay the pipes and hoses with a gradient (50 mm/m) to ensure that they can run empty.
- Pipe dimensions: (→ Technical data)

Fitting the DN 110 outlet

BioTec ScreenMatic² 140000: The outlet is not fitted on delivery.

Prerequisite:

- The container is open. (→ Opening the container)

How to proceed:

J

1. Fit the O ring onto the outlet.
2. Fit the outlet into the respective hole of the container wall from the outside.
 - Ensure that the raised marking is at the top and aligned in relation to the hole pattern.
3. Fasten the outlet from the inside with oval head screws.
 - Tighten all screws diagonally using the cordless screwdriver to ensure that the sealing ring is uniformly applied. Further tighten the screws using a Phillips screwdriver.



NOTE

Build supports to increase the stability of the pipe construction and to prevent the pipe construction from sagging at the discharge.

4.5 Connecting the dirt outlet

The water in the container can be drained via the dirt outlet with slide valve at the bottom of the container when required (for cleaning, repair, overwintering).

- Connect the pipe and drain the dirty water, for example, into a flower bed or into the sewage system.
- Pipe dimensions: (→ Technical data)

4.6 Carry out the electrical connection

How to proceed:

K

1. Thread the connection cable through the opening in the container wall and seal off the opening using the sealing plug.
 - Ensure that the connection cable inside the container is sufficiently long so that it is not subjected to tension when the ScreenMatic rotating screen unit is hinged up.
 - Avoid tangling of the cable inside the container.
2. Connect the plug of the connection cable to the socket on the transformer and hand-tighten the union nut.

5 Commissioning/start-up



NOTE

Remove the protective film from the substrate tubes and insert the substrate tubes into the container. (→ Cleaning/replacing the substrate tubes)

- The substrate tubes are sealed in protective film on delivery.
- Thoroughly clean the pond before starting up the filter system for the first time to ensure that the filter system is not overloaded by excessively soiled water. OASE recommends using the PondoVac pond vacuum cleaner for cleaning the pond.
 - This cleaning measure is normally not necessary for newly installed ponds.
- It is necessary to operate the filter system for 24 hours a day during the pond season.

5.1 Biological filter starter

The foam filters take several weeks to reach their full biological cleaning effect. We recommend using the OASE filter starter Biokick to ensure fast growth of bacterial populations. Micro-organisms colonise the filter system, multiply and ensure an enhanced quality of the pond water by the decomposition of excess nutrients.



NOTE

When using filter starter, medicines or pond water treatments, leave the UVC clarifying unit switched off for at least 36 hours so as not to impair their efficacy.

5.2 Order of starting up steps

How to proceed:

1. Close the slide valve of the dirt outlet.
2. Check that the filter system (pipes and hoses) is complete.
3. Remove the container cover.
4. Connect the transformer for the control device to the power supply.
5. Switch on the filter pump and UVC clarifier (if applicable).
 - Ensure that the water is returned to the pond via the return pipe.
6. Check all pipes, hoses and their connections for leaks.
 - Expansion seals may leak initially until they have fully expanded on contact with water.
7. Adjust the control device to the flow rate if necessary. (→ Aligning the control device)
8. Check the function of the ScreenMatic rotating screen unit. (→ Operation)
9. Fit the container cover.



NOTE

The final water level is not reached in the container until the bacteria are established and the filter becomes fully effective.

- New foam filters take 3 to 4 weeks to reach their full biological cleaning effect. The water level is initially lower; the foam filters are not completely covered by the water. The filter may overflow while the beneficial bacteria colonies are being established. Do not clean the foam filters for 3 to 4 weeks.
- The biological cleaning effect ceases at temperatures under 10 °C. The filter may overflow. Cleaning is not necessary.



NOTE

The substrate tubes should remain completely under water to ensure maximum effectiveness. Depending on the system configuration, the level of the water in the container may be too low for this.

- In this case, place the top substrate tube directly into the pond at a point where there is good water circulation.

5.3 Aligning the control device

Do not align the control device until after the running-in period

- Lowering the pump into the pond may swirl up so much debris that starting up the filter system straight away could cause the ScreenMatic screen to overflow.
- The filter system requires a running-in period of 2 to 3 hours. After this, the control device can be aligned if necessary.

- Align the control device such that the sensor only switches when a well-formed line of debris has formed on the screen.
 - A well-formed line of debris can be optimally removed by the stripper and conveyed into the debris tray.
 - The stripper brush under the ScreenMatic screen collects the fine debris, which falls into the debris tray.

How to proceed:

L

- Remove the screw from the control device and take out the control device.
- Insert the control device into the determined position, insert the screw and hand tighten.

Aligning the control device depending on the degree of soiling of the pond

In order to prevent premature soiling of the foam filters, ensure that the dirty water does not flow beyond the "Max. water jet" mark directly into the debris tray.

- Do not change the position of the control device unless the water flows as far as or beyond the "Max. water jet" mark, even when the ScreenMatic screen has been cleaned (with the enclosed brush).
(→ Cleaning/replacing the ScreenMatic screen)

Typical position of the control device

BioTec ScreenMatic ² 40000		BioTec ScreenMatic ² 60000		BioTec ScreenMatic ² 90000		BioTec ScreenMatic ² 140000	
<6000 l/h	<7	<8000 l/h	<9	<9000 l/h	<10	<12000 l/h	<18
>8000 l/h	>7	>9000 l/h	>9	>11000 l/h	>10	>15000 l/h	>18
Delivery state	7	Delivery state	9	Delivery state	10	Delivery state	18

6 Operation

6.1 Operating panel

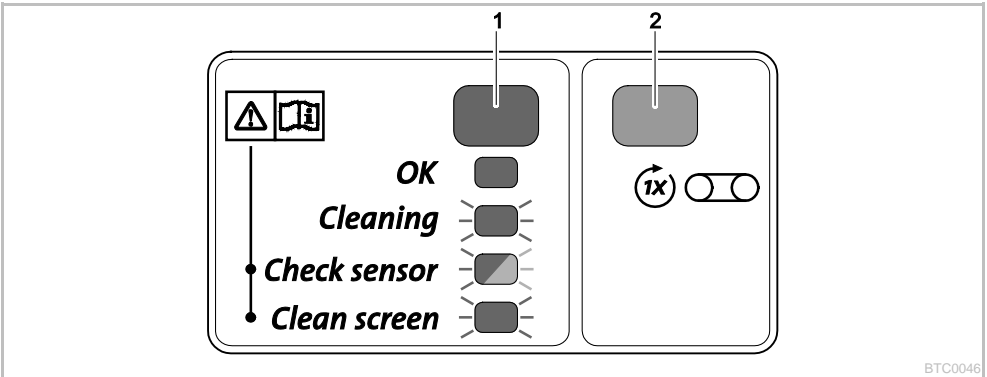

BTC0046

1	LED, 2 colours	
	• Lit green	The ScreenMatic rotating screen unit is operational
	• Flashes green	Cleaning active
	• Flashes green/red	Malfunction (→ System messages)
	• Flashes red	Malfunction (→ System messages)
2	Button, start/stop manual cleaning	(→ Manual cleaning)

6.2 Manual cleaning

Proceed as follows	Description
Press for 1 s.	The ScreenMatic screen is rotated by 1 revolution. <ul style="list-style-type: none"> Press the button again for 1 s: The rotational movement stops prematurely.

6.3 Automatic cleaning

Due to the build-up of debris the water level on the ScreenMatic screen also rises. When the sensor in the control device comes into contact with the water, it triggers the rotational movement of the ScreenMatic screen.

By briefly moving the ScreenMatic screen back several times a larger line of debris is formed, which can be better removed by the stripper.

Sequence of an automatic cleaning cycle	Rotational movement of the ScreenMatic screen
Normal soiling	
1. Contact of the sensor with water	Brief movement backward
2. Contact of the sensor with water	Brief movement backward
3. Contact of the sensor with water	Brief movement backward
4. Contact of the sensor with water	One rotation forward <ul style="list-style-type: none"> The debris is conveyed into the debris tray.
Heavy soiling or incorrectly aligned control device (permanently high water level on the ScreenMatic screen)	
1. Contact of the sensor with water	Brief movement backward, then one rotation forward <ul style="list-style-type: none"> The debris is conveyed into the debris tray.

6.4 Time-dependent cleaning

The ScreenMatic rotating screen unit executes a cleaning cycle after a set interval depending on the ambient temperature. This ensures cleaning at regular intervals

- if the sensor is soiled or defective,
- if there is very little soiling on the screen and/or low flow rates (e.g. when the SFC of the filter pump is activated).

Ambient temperature	Interval	Rotational movement of the ScreenMatic screen
≤10 °C	6 hours	One rotation forward
10 °C ... 20 °C	4 hours	<ul style="list-style-type: none"> The debris is conveyed into the debris tray.
≥20 °C	3 hours	

6.5 System messages

LED	Malfunction	Possible cause	Remedy	Resetting the system message
Flashes green/red	No automatic cleaning cycle within 48 hours	Sensor soiled	<ul style="list-style-type: none"> Clean the sensor. Descale the sensor. 	Automatic reset after remedy of malfunction
		No dirty water, cleaning is not necessary	–	
	No flow of water	Filter pump is not operating	Start up the filter pump.	
	No water detected by the sensor	Control device incorrectly positioned	Correctly position the control device	
		Control device defective	Replace the control device.	
		Insufficient conductivity of the water	Increase the water hardness with OptiPond	
	Insufficient pump capacity	Adjust the pump capacity accordingly		
Flashes red	20 automatic cleaning cycles in succession	ScreenMatic screen soiled	<ul style="list-style-type: none"> Start manual the cleaning cycle and use a brush to clean the ScreenMatic screen on the side of the water distributor (→ Manual cleaning) Clean the ScreenMatic screen from the inside if the mesh is clogged by a biofilm (→ Cleaning/replacing the ScreenMatic screen) 	Automatic reset after remedy of malfunction
		Sensor soiled	Clean the sensor.	
		Control device incorrectly positioned	Correctly position the control device	
		Pump capacity too high	Adjust the pump capacity accordingly	
Flashes green	ScreenMatic screen not rotating although a manual	Motor cable plug not connected or incorrectly connected to the control device	Connect the plug, check that it is correctly seated.	–

LED	Malfunction	Possible cause	Remedy	Resetting the system message
	cleaning cycle was triggered.	Motor defective	Replace motor	
Off	ScreenMatic screen not rotating although a manual cleaning cycle was triggered.	Connection cable plug not connected or incorrectly connected to the transformer	Connect the plug, check that it is correctly seated.	-
		Transformer not connected to the mains voltage	Connect the transformer to the mains voltage.	
		Transformer defective	Replace transformer	
		Control device defective	Replace the control device.	

7 Remedy of faults

Malfunction	Possible cause	Remedy
No flow of water	Filter pump not switched on.	Switch on the filter pump, connect the power plug.
	Supply to filter system or return to pond blocked.	Clean the supply and/or return.
Water flow insufficient	Hose kinked or clogged	Check, clean or replace the hose if necessary.
	Excessive loss in the hoses due to friction	Reduce hose length to reduce frictional loss
	Insufficient pump capacity	Adjust the pump capacity accordingly
Water remains cloudy	Insufficient circulation of the water	Adjust the pump capacity accordingly
	The water is extremely soiled.	<ul style="list-style-type: none"> Optimise the circulation of the water in the pond. Remove algae and leaves from the pond. Change the water. If the water is particularly contaminated, change 30% of the water to avoid damage to the fish.
	Too many pond animals	Reduce number of pond animals Guide value: approx. 600 mm fish length per 1 m ³ pond water
	ScreenMatic screen is clogged	Clean or replace the ScreenMatic screen.
No water at the pond inlet	Foam filters soiled	Clean foam filters
	Pond inlet blocked	Clean the pond inlet.
Water level in the container too low, foam filters are not completely immersed in water.	Filter pump is not operating.	Start up the filter pump.
	The water level is initially lower when new foam filters are fitted as they have not yet been colonised by bacteria.	<ul style="list-style-type: none"> It takes several weeks for the bacteria to become established and the foam filters to become fully effective. Use OASE filter starter Biokick to speed up the colonisation of bacteria.
	The separating plate is missing. (Only BioTec ScreenMatic ² 40000/60000/90000)	Insert the separating plate.
Increased noise	Noise of water at the outlet due to insufficient aeration	Insert a tee into the discharge pipe with the opening pointing up for aeration.

8 Maintenance and cleaning



WARNING

Possible death or severe injury from hazardous electrical voltage!

- Prior to reaching into the water, isolate (switch off and disconnect) all units/devices used in the water.
- Isolate the device (disconnect from the power supply) before carrying out any work on it.
- Do not use aggressive cleaning agents or chemical solutions as they could attack the housing or impair the function of the unit.
- Recommended cleaning agent for removing stubborn limescale deposits:
 - Pump cleaning agent PumpClean from OASE.
 - Vinegar- and chlorine-free household cleaning agent.
- After cleaning, thoroughly rinse all parts in clean water.

8.1 Regular cleaning work

- Empty the debris tray:
 - The cleaning cycle is dependent on the degree of soiling of the pond.
 - Remove the debris tray. (→ Hinging the screen holder up/down)

- Clean the ScreenMatic screen:
 - If the ScreenMatic screen becomes clogged, clean the ScreenMatic screen downstream of the water distributor using the brush. For this, manually activate the ScreenMatic screen. (→ Manual cleaning)
 - Carry out intensive cleaning with the pump cleaning agent PumpClean from OASE: (→ Cleaning/replacing the ScreenMatic screen)

8.2 Cleaning foam filters

- It is necessary to clean the foam filters as soon as the water exceeds the 100% mark on the separating plate.
- Do not use any chemical cleaning agents as they would kill the filter bacteria.

Prerequisite:

- The filter pump is switched off.
- The container is open. (→ Opening the container)
- The screen holder is hinged up. (→ Hinging the screen holder up/down)
- BioTec ScreenMatic² 90000: Separating plate has been pulled out and the substrate tubes have been removed. (→ Cleaning/replacing the substrate tubes)
- The water level in the container has lowered to the height of the outlet or below.

How to proceed:

M, N

BioTec ScreenMatic² 40000/60000/90000:

1. Insert the plug into the outlet from the inside to close off the outlet.
 - Remove the separating plate to facilitate access if applicable.
2. Switch on the filter pump until the foam filters are covered with water, then switch off the filter pump.
3. Compress all foam filters several times with the foam cleaning device.
4. Allow the dirty water to drain away.
 - Open the dirt outlet slide valve and close it again when the container is empty.
5. Repeat steps 2 ... 4 as required.
6. Rinse the container with clear water to remove any loosened dirt particles. To do this, first carry out step 2, then step 4.
7. Remove the plug from the inside of the outlet.
8. Close the dirt outlet slide valve.
9. Hinge down the screen holder (→ Hinging the screen holder up/down), insert the debris tray and switch on the filter pump.

O

BioTec ScreenMatic² 140000:

1. Insert the plug into the outlet from the inside to close off the outlet.
2. Switch on the filter pump until the foam filters are covered with water, then switch off the filter pump.
3. Compress all foam filters several times with the foam cleaning device.
4. Allow the dirty water to drain away.
 - Open the dirt outlet slide valve and close it again when the container is empty.
5. Repeat steps 2 ... 4 as required.
6. Rinse the container with clear water to remove any loosened dirt particles. To do this, first carry out step 2, then step 4.
7. Remove the plug from the inside of the outlet.
8. Close the dirt outlet slide valve.
9. Hinge down the screen holder (→ Hinging the screen holder up/down), insert the debris tray and switch on the filter pump.

8.3 Cleaning/replacing the substrate tubes

The substrate tubes are filled with zeolite on delivery. OASE recommends replacing the zeolite with Phosless when the bacteria are established and the foam filters are fully effective.

Prerequisite:

- The filter pump is switched off.
- The container is open. (→ Opening the container)
- The screen holder is hinged up. (→ Hinging the screen holder up/down)

How to proceed:

P

BioTec ScreenMatic² 40000/60000:

1. Remove the separating plate.
2. Remove the substrate tubes and clean them or replace their contents.
 - BioTec ScreenMatic² 40000: Two substrate tubes
 - BioTec ScreenMatic² 60000: Three substrate tubes
 - When inserting, push the substrate tubes against the wall opposite to the outlet.

Q

BioTec ScreenMatic² 90000:

1. Remove the separating plate.
2. Remove the substrate tubes and clean them or replace their contents.
 - BioTec ScreenMatic² 90000: Four substrate tubes
 - Two substrate tubes each to the left of the outlet and two substrate tubes each to the right of the outlet.

R

BioTec ScreenMatic² 140000:

- Remove the substrate tubes individually and clean them or replace their contents.
 - BioTec ScreenMatic² 140000: Twelve substrate tubes

8.4 Cleaning/replacing the ScreenMatic screen

Prerequisite:

- The filter pump is switched off.
- The container is open. (→ Opening the container)
- The debris tray is removed. (→ Hinging the screen holder up/down)

How to proceed:

S

1. Remove the screw for fastening the control device, remove the control device and place it carefully to the side.
 - If necessary, disconnect the motor cable plug from the control device.
 - Mark the position of the control device on a side section for reassembly.
2. Take the ScreenMatic rotating screen unit out of the screen holder.
 - Biotec ScreenMatic² 40000/60000/90000: Press the locking clips on both sides and remove the ScreenMatic rotating screen unit.
 - Biotec ScreenMatic² 140000: Press the ScreenMatic rotating screen unit in the direction of the water distributor and remove.
3. Undo the nuts on the side section, and remove the side section and stripper.
4. Release the clamping lever and remove the ScreenMatic screen.
 - Thoroughly clean the stripper.
 - Thoroughly clean both sides of the ScreenMatic screen. Replace the ScreenMatic screen if necessary.
 - Use the pump cleaning agent PumpClean from OASE.
5. Reassemble the ScreenMatic rotating screen unit in the reverse order and place it into the screen holder.
 - When tensioning the ScreenMatic screen, ensure that the clamping lever engages.

8.5 Replacing foam filters

Prerequisite:

- The filter pump is switched off.
- The container is open. (→ Opening the container)
- The screen holder is hinged up. (→ Hinging the screen holder up/down)

How to proceed:

T

1. Press both locking clips on the foam holder.
2. Remove the foam holder plate and foam filter.
3. Push a new foam filter onto the foam holder, fit the foam holder plate and push down until the two locking clips engage in the foam holder plate.



NOTE

Recommendation regarding the replacement of foam filters:

- Only partially replace the foam filters at intervals of at least a week so as not to impair the biological cleaning action too much.

- Never replace more than 50 % of the foam filters at any one time.

9 Storage/overwintering

The unit is protected from frost:

The unit can be operated as long as the water temperature does not go below +4 °C.

The deeper areas of the pond have a water temperature of approx. +4 °C in winter and are essential for the fish. By taking the following measures it is possible to reduce the cooling effect on the water of the circulation by the filter system:

- Position the pump nearer to the surface of the water so that only colder water closer to the surface of the pond enters the pump.
- Insulate the return pipes from the filter system into the pond.
- Do not allow water to flow into the pond via a water course.

The unit is not protected from frost:

Take the unit out of operation at water temperatures below +8° C or, at the latest, when freezing temperatures are to be expected.

- Drain the unit as far as possible, clean thoroughly and check for damage.
- Empty all hoses, pipes and connections as far as possible.
- Leave the slide valves open.
- Cover the filter container to prevent the penetration of rain water.
- Protect pipes and slide valves that are in contact with water from frost.

10 Wear parts

The following components are wear parts and are excluded from the warranty:

- Foam filters
- Substrate tubes
- ScreenMatic screen

11 Disposal



NOTE

Do not dispose of this unit with domestic waste.

- Render the unit unusable beforehand by cutting the cables and dispose of the unit via the return system provided for this purpose.

12 Technical data

Description			BioTec ScreenMatic ²			
			40000	60000	90000	140000
Power pack	Primary rated voltage	V AC	230	230	230	230
	Mains frequency	Hz	50	50	50	50
	Secondary rated voltage	V DC	12	12	12	12
	Permissible ambient temperature	°C	-10 ... +35	-10 ... +35	-10 ... +35	-10 ... +35
Control device	Power consumption	W	5	5	5	5
	Permissible ambient temperature	°C	-10 ... +35	-10 ... +35	-10 ... +35	-10 ... +35
Cable length	Power pack	m	2.10	2.10	2.10	2.10
	Control device	m	5.00	5.00	5.00	5.00
Foam filter	Number of blue foam filters	pce.	2	2	4	4
	Number of red foam filters	pce.	3	3	6	7
	Number of purple foam filters	pce.	3	3	6	7
Special filter pellets	kg	2.50	3.50	5	14.50	
Removal of coarse dirt particles	µm	300	300	300	300	
Permissible water temperature	°C	+4 ... +35	+4 ... +35	+4 ... +35	+4 ... +35	
Inlet	Quantity	pce.	2	2	2	2
	Connection, hose	mm	25, 32, 38	25, 32, 38	25, 32, 38, 50	25, 32, 38, 50
			G1, G1¼, G1½	G1, G1¼, G1½	G1, G1¼, G1½, G2	G1, G1¼, G1½, G2
	Connection, UVC clarifier		Bitron C 36 W / 55 W / 72 W / 110 W Bitron Eco 120 W / 180 W / 240 W Vitronic 18 W / 24 W / 36 W			
Outlet	Quantity	pce.	1	1	1	1
	Connection		DN 75	DN 75	DN 110	DN 110
Dirt outlet	Quantity	pce.	1	1	1	1
	Connection		DN 50	DN 50	DN 50	DN 75
Circulation capacity	Min.	l/h	4000	6000	8000	8000
	Max.	l/h	9000	11000	12500	17500
Maximum pond volume	Without fish population	m ³	40	60	90	140
	With fish population	m ³	20	30	45	70
	Including koi carp	m ³	10	15	22.5	35
Dimensions	Length	mm	788	788	788	1200
	Width	mm	590	590	590	800
	Height	mm	454	554	654	760
Weight	Without water	kg	20	25	30	95

13 Spare parts

The use of original parts from OASE ensures continued safe and reliable operation of the unit. Please visit our website for spare parts drawings and spare parts.



www.oase-livingwater.com/spareparts-di